

GSC/GSE

Compact/Sound Proof Granulators



ZERMA
The Home of Size Reduction



Compact/Sound Proof Granulators: GSC

The GSC compact/sound proof granulator series are designed with a fully enclosed sound proof box enclosure resulting in extremely quiet operation. The sound proof enclosure ensures easy and quick access to the cutting chamber during rotor/stator knife servicing and screen removal. The sound proof material used is based on the latest technological research.

The completely welded cutting chamber in conjunction with the "V" type rotor design ensures dependability in operation and universal applications use. The cutting geometry of the GSC series allows material feed injection even with voluminous types of material. The complete GSC series line achieves a high quality granulate irrelevant of the material type such as injection moulded parts, blow moulded parts, profiles, sheet, film, etc.

Features and Advantages:

- Cutting chamber wear plates are standard
- Outboard Rotor Bearings
- Drop Down Screen Cradle
- Reversible screen
- "Clam Shell" Opening of Upper Cutting Chamber.
- "V" Cut Rotor/Stator Knife Configuration
- Double Sided Stator Knives



GSC Type 300/300 with integrated blower system



GSC Type 500/700



Compact sound proof design

The design of the GSC granulators in terms of material and construction, offers the best sound dampening characteristics combined with quick and easy access to the inner machine parts for servicing and maintenance work. The granulator is built as a compact unit that can be moved or transported easily by a fork lift or standard lifting device.





Economical Granulators: GSE

The machines of the GSE series are based on the GSC model, and inherit its technology and advantages. The GSE machines are identical in nature but without the soundproofed housing to offer a more economical and compact machine without sacrificing usability and versatility.

The GSC and GSE series machines are economically priced, reliable, easy to clean and ensures a dependable operating unit.

ZERMA offers a wide range of accessories to enhance the GSC and GSE series such as upgraded material transport systems, conveyor belts, metal separators and fine separators.

Material Transport System:

The GSE machines are equipped with a material transport system and single bagging station as standard.

Optionally, the GSE machines can be equipped with a stainless-steel material drawer to collect the ground in-feed materials.





Simplified Knife Adjustment:

Knife adjustment is performed totally outside the granulator prior to installation with the assistance of a knife adjustment fixture that is provided with the machine. The rotor and stator knives are manufactured from high tensile strength steel and can be re-sharpened numerous times.



Unique Chevron Cutting Geometry:

The rotor knives are designed with the latest "V" cut technology. In comparison to the standard full angled knives, the "V" cut design creates a consistent material cutting concentration centered around the middle area of the rotor for ultimate size reduction. The "V" type chevron cutting configuration reduces knife wear and eliminates excessive cutting chamber side wall wear.



Maximum Material In-feed:

The GSC series cutting chamber and rotor are engineered to ensure consistent material pull-in to achieve a high quality regrind from any in-feed material and avoid bridging of voluminous and bulky parts on the rotor.



Different Applications require different machine setups, the GSC range of machines can be tailored to a wide variety of applications.

3-Blade Rotor:

Depending on the specific application the GSC and GSE machines are equipped with 3 knife high shear rotor. The high shear open rotor gives you increased flexibility. It is ideal for big voluminous parts as well as smaller parts and inline or central applications. For more specialized applications Zerma offers optional rotors to choose from.

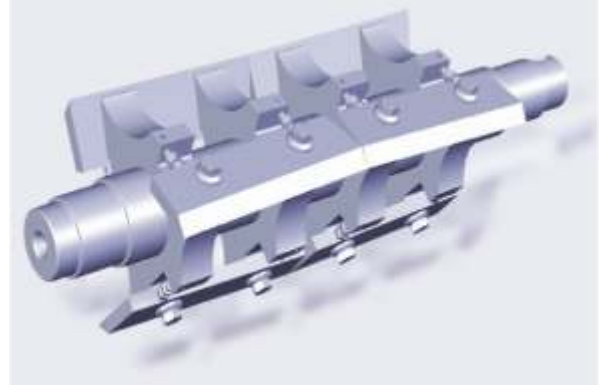

5-Blade Rotor:

In addition to our standard 3 blade high shear open rotor the GSC 500 and 700 series machines are available with a high shear open 5 blade rotor, which yields more cuts per revolution and assists in reducing material duration time in the cutting chamber.

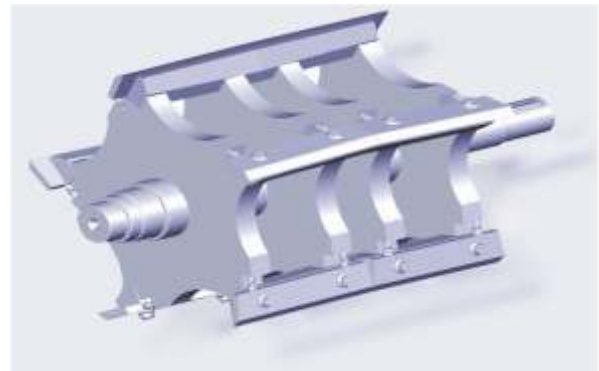

S-Type Rotor:

Apart from the 3 and 5 knife high shear rotor we also offer the S-3 and S-5 type rotors from our GS and GSH series as an option for the GSC and GSE range of machines. The S rotor absorbs excessive shock and reduces rotor aggressiveness.



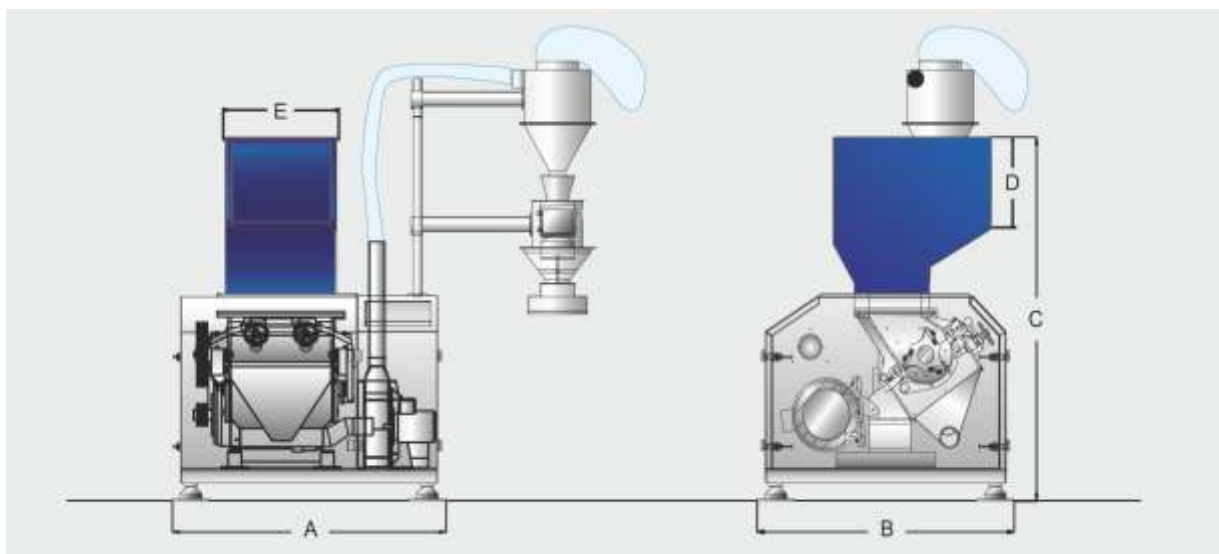

Type GSC	300/300*	300/600*	300/1000	500/500*
Rotor diameter (mm)	300	300	300	500
Rotor width (mm)	300	590	990	500
Cutting chamber cross section (mm x mm)	315 x 300	315 x 590	315 x 990	515 x 500
Drive capacity (kW)	7,5 - 11	11 - 18,5	18,5 - 22	22 - 37
Dimensiones:				
Width A (mm)	1360	1650	1900	1300
Length B (mm)	1550	1550	1550	1900
Height C (mm)	2050	2050	2050	2450

Type GSC	500/700	500/1000	700/700	700/1000
Rotor diameter (mm)	500	500	700	700
Rotor width (mm)	700	990	700	990
Cutting chamber cross section (mm x mm)	515 x 700	515 x 990	715 x 700	715 x 990
Drive capacity (kW)	30 - 45	37 - 55	45 - 55	45 - 75
Dimensiones:				
Width A (mm)	1500	1800	1500	1800
Length B (mm)	1900	1900	2200	2200
Height C (mm)	2450	2450	2950	2950

* Machines are available with integrated blower

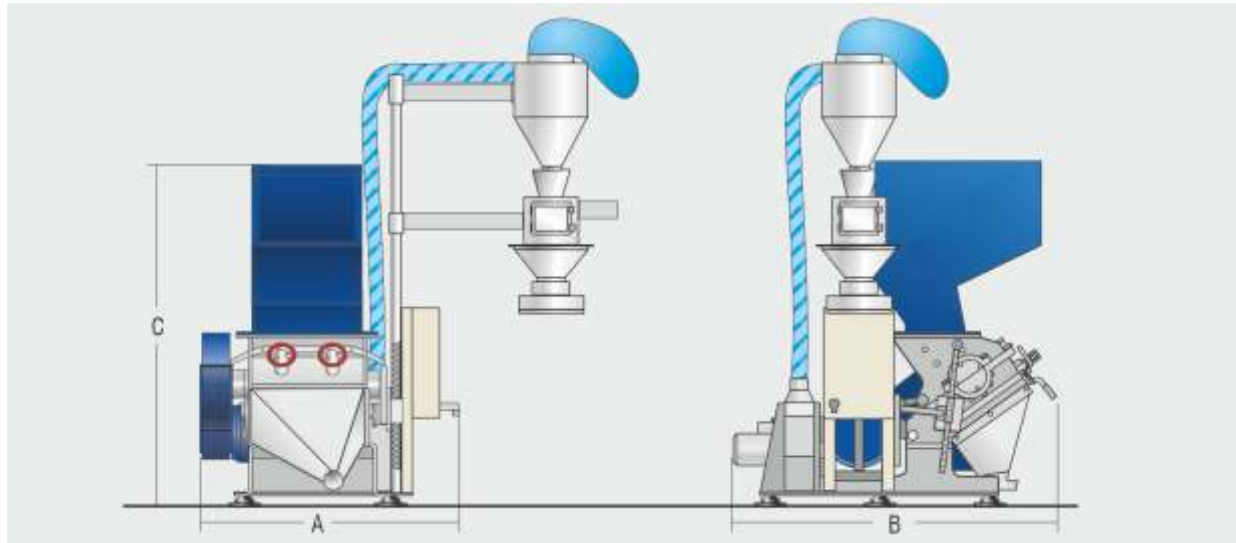

Type GSE	300/300	300/600	300/1000	500/500
Rotor diameter(mm)	300	300	300	500
Rotor width (mm)	300	590	990	500
Cutting chamber cross section (mm x mm)	315 x 300	315 x 590	315 x 990	515 x 500
Drive capacity (kW)	7,5 - 11	11 - 18,5	18,5 - 22	22 - 37
Dimensiones:				
Width A (mm)	1100	1380	1620	1210
Length B (mm)	1660	1700	1300	1610
Height C (mm)	1900	1900	1900	2400

Type GSE	500/700	500/1000	700/700	700/1000
Rotor diameter (mm)	500	500	700	700
Rotor width (mm)	700	990	700	990
Cutting chamber cross section (mm x mm)	515 x 700	515 x 990	715 x 700	715 x 990
Drive capacity (kW)	30 - 45	37 - 55	45 - 55	45 - 75
Dimensiones:				
Width A (mm)	1410	1710	1300	1600
Length B (mm)	1610	2000	2270	2270
Height C (mm)	2400	2400	2750	2750

Subject to technical modification



ZERMA

ZERMA Recycling & Granulator Technology



ZERMA, with more than 60 years of experience, is one of the leading manufacturers of high quality granulators. Our product range begins with the small slow, speed granulators and reaches the large high performance granulators, including special machines such as the front entry granulators for pipes and profiles or the pulveriser systems for fine grinding applications. Using drive motors ranging from 2,2 kW to 200 kW, the ZERMA line of machines covers the complete spectrum of plastics size reduction applications.

www.amis-gmbh.de



AMIS Maschinen-Vertriebs GmbH
 Im Rohrbusch 15
 74939 Zuzenhausen · Germany
 Phone: +49 (0) 6226 7890-0
 Fax: +49 (0) 6226 7890-222
info@amis-gmbh.de



Subject to technical modification 09/2010, V 1.0

ULTIMATE SIZE REDUCTION TECHNOLOGY