

INNOVATIONS

BARTH > Catalogue 2021 > English

21.0



LIFTING TABLES



ASSEMBLY TABLES



TURNING/ROTATING



VACUUM PRESSES

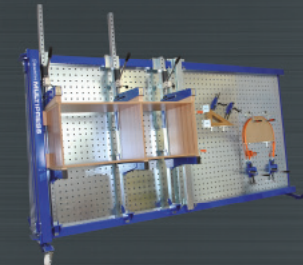

BONDING PRESSES



GRINDING MACHINE

LIFTING TABLES | WORK TABLES | VACUUM PRESSES | BONDING PRESSES

Benefit from our experience

Instant information:

+49 8634 9827 0
info@barth-maschinenbau.de

BARTH GmbH
 Gerhard-Meister-Str. 5
 83342 Tacherting
 GERMANY
 Phone: +49 8634 9827 0
www.barth-maschinenbau.de



EXPERIENCE BARTH

Ask us - we will be glad to assist you:

- › in selecting the right lifting table and work table
- › in optimizing your bench area
- › in finding a solution for your assembly problems with our tailor-made press solutions
- › for difficult applications with our vacuum presses

We are looking forward to your visit.

Opening hours

Monday – Thursday:

8 am – 12 am and

1 pm – 5 pm

Friday:

8 am – 1 pm

Google Maps:



TABLE OF CONTENTS

LIFTING TABLES



06

WORK/ASSEMBLY TABLES



14

WORKPLACE DESIGN



23

TURNING AND PIVOTING TABLES



26

VACUUM PRESSES



36

VACUUM BAGS AND PUMPS



47

Advantages BARTH.....04

Overview of lifting and work tables.....05

Lifting tables 06 - 12

Accessories for lifting tables 13

Work/assembly tables 14 - 19

Accessories for work/assembly tables 20 - 22

Workplace design23 - 25

Turning and pivoting tables.....26 - 34

Overview of vacuum presses35

Vacuum presses 36 - 45

Vacuum presses 46

Vacuum bag 47

Accessories for vacuum presses..... 48

Overview of MULTI-presses.....50 - 51

MULTI-presses 52 - 62

Benefits of manual hydraulics HSH01 63

Overview of unit variants for MULTI-presses 64

Accessories for MULTI-presses 65 - 66

Round and chamfer grinding machines68 - 69

Swivelling fence for sliding table saws.....70

MULTI-PRESSES



52

GRINDING MACHINE



68

Optimize your assembly workplace!

Profits are hidden at any workplace.



USER VIDEO
www.barth.tv



The video shows a modern, ergonomic and above all economical assembly workplace. See for yourself!

BARTH – it's your decision



QUALITY AND FUNCTION IN HARMONY

We fulfil your highest demands in terms of product quality and functionality and, thus meet the high European requirements regarding the suitability of our products.



OPEN AND HONEST ADVICE

Well-founded and individual advice is important to us. This is how we find the optimal solution for your application.



EFFICIENCY

Our innovative products are not only economical, but also ergonomically. This is how you preserve your health.



MADE IN GERMANY

We manufacture in Germany to provide perspectives and, we take responsibility for employees and junior staff for a future with opportunities.



SPECIAL SOLUTIONS

If you are looking for innovative solutions for your work processes, you can rely on our experience.

Overview of BARTH lifting and assembly tables

H 300

Page 06



- > Worktop: 1,245 x 740 mm
- > Max. load: 300 kg

H 350 XL

Page 08



- > Worktop: 2,000 x 1,015 mm
- > Max. load: 350 kg

H 600

Page 10



- > Worktop: 2,000 x 1,015 mm
- > Max. load: 600 kg

H 850

Page 10



- > Worktop: 2,000 x 1,015 mm
- > Max. load: 850 kg

H 1000

Page 12



- > Worktop: 2,000 x 1,015 mm
- > Max. load: 1,000 kg

vakuuCAR

Page 16



- > Worktop: 1,350 / 1800 x 800 mm
- > Max. load: 75 kg

vakuuLIFT-S

Page 18



- > Worktop: 2,000 x 1,015 mm
- > Max. load: 350 kg



Instant information:
☎ +49 8634 9827 0
info@barth-maschinenbau.de

Essential helper for any workshop

Lifting table H 300

This lightweight and flexible lifting table is ideal as little helper in your workshop. This table may be used for storing parts or for transporting smaller parts from one machine to another. The large adjustment range always ensures the optimum working height.



H 300 in control box assembly



solid welded construction of the cylinder holder (maximum shear force 1.2 t)

- 
EASY TO HANDLE
 perfect size and weight for a transport cart, with milled grips in the worktop
- 
EXTREMELY VERSATILE
 the steering rollers allow longitudinal or cross movements, for long parts, 2 steering rollers can be locked in this direction
- 
STURDY
 hydraulics with overload protection
- 
MOBILE
 smooth-running casters having a diameter of 125 mm
- 
LARGE ADJUSTMENT RANGE

Base version lifting table 300

- > Multiplex worktop with 2 grips, 1,245 x 740 mm
- > Load 300 kg
- > Base frame in solid construction
- > Foot-pumped hydraulic system with overload protection
- > 2 steering rollers with brake \varnothing 125 mm
- > 2 steering rollers with direction lock 125 mm \varnothing
- > Delivery in a ready assembled condition
- > Footprint L x W x H:
1,350 x 740 x 490 – 1,070 mm

Variant work table H 300 accuDRIVE (12 V)

Variant work table H 300 eDRIVE (230 V)

Different types of height adjustment are available

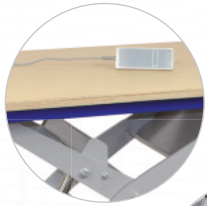

> eDRIVE variant



> accuDRIVE variant

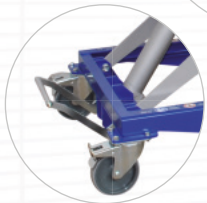

> Standard foot-pumped hydraulic system



For worktops, refer to page 13



USER VIDEO
www.barth.tv



- 01 Large adjustment range from 490mm - 1.070 mm
- 02 Foot-pumped hydraulic system comfortable and smooth-running with overload protection

- 03 High-quality castors smooth-running, 2x with brake and 2x with direction lock

- 04 Sturdy base structure optional with transport support for forklift forks

- 05 Solid worktop birch multiplex, 1,245x740x24 mm. Optional hole plate 1,500x800x30 mm, (BH-17-70)

The flexible "trestle substitute" and assembly table

Lifting and work table series XL

The lifting and work table H 350 XL is a modern, mobile work table with large worktop which individually and ergonomically adapts to your workpieces and especially to your posture. The height is adjusted by a foot-pumped hydraulic system which can be operated from both

longitudinal sides. The easy-to-operate hydraulic unit always drives the work top to the desired height position. The large adjustment range from 500 mm to 1,150 mm offers you the advantage that both small and large workpieces can be processed at a comfortable working height.



ERGONOMIC
always adjustable to the appropriate height



COMFORTABLE
foot-pumped hydraulic system, operable on both sides



QUALITY
sturdy steel structure
foot pump with overload protection
powder-coated surfaces



FLEXIBLE
with Multiplex worktop
1,015 x 2,000 mm, optionally
extendable with longitudinal pull-outs



MOBILE
large sized 125 mm Ø steering
rollers, 2 with brake and
2 with directional lock



Lifting table H 350 XL with hole plate and various accessories (optional)

Recommendation Accessory kit wooden hole plate 3x rack-and-pinion gear small, 4x stop block, 2x vertical clamping device (BH-12-35)

Various additional accessories refer to page 21



Longitudinal pull-out (optional) on both sides, 550 mm each

Base version lifting table H 350 XL

- > H 350 XL with multiplex plate 2,000 x 1,015 x 24 mm, load capacity 350 kg
- > Base frame in solid construction
- > Foot-pumped hydraulic system with overload protection
- > Operation of hydraulic system on both sides
- > 2 steering rollers with brake Ø 125 mm
- > 2 steering rollers with direction lock 125 mm Ø
- > Footprint L x W x H: 2,000 x 1,015 x 500 up to 1,150 mm

Variant Work table H 350 XL accuDRIVE (12 V) with multiplex plate, load capacity 300 kg, max. height 1,120 mm

Variant Work table H 350 XL eDRIVE (230 V) with multiplex plate, load capacity 300 kg, max. height 1,080 mm

Different types of height adjustment are available

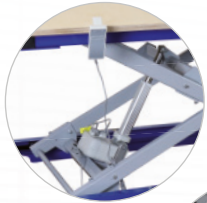

> eDRIVE variant



> accuDRIVE variant

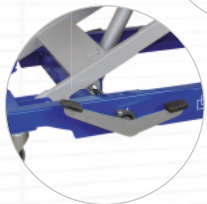

> Standard foot-pumped hydraulic system



For worktops, refer to page 13



USER VIDEO
www.barth.tv

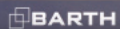

- 01 High-quality castors
smooth-running, 2x with brake
and 2x with direction lock
- 02 Foot-pumped hydraulic system
on both sides, operable on both
longitudinal sides with overload protection
- 03 Sturdy base structure
height adjustable: 500–1,150 mm
- 04 Sturdy scissors-type structure
for uniform load holding
- 05 Worktop
Standard: 2,000 mm x 1,015 mm
expandable with longitudinal and cross
pull-outs to max. 3,200 x 2,200 mm

The power package with quick stroke Lifting table H 600 / H 850

The work and lifting tables of the 600 or 850 series handle more weight without any problems. Workpieces up to a weight of 600 kg or 850 kg can be processed, lifted and transported without any problems. Height adjustment is ensured by a 2-step quick stroke hydraulic system and can be adjusted continuously from 450 mm to 1,100 mm.



The foot pump chooses automatically the right step:
1st step: Quick lift for small loads
2nd step: Easy lift for loads of 600 kg or 850 kg



Base version of lifting table H 600 / 850

- > Lifting table 600, without worktop,
Load capacity 600 kg
- > Lifting table 850, without worktop,
Load capacity 850 kg
- > 2 steering rollers with brake
- > 2 castors
- > 2-step foot-pumped hydraulic system,
optionally attached to the front or
longitudinal side
- > Footprint Lx WxH:
2,000 x 1,015 x 450 – 1,100 mm

Various accessories such as hole plates, longitudinal pull-outs are available. Refer to pages 13 and 21

Lifting table H 600 / H 850



SMOOTH-RUNNING

2-step quick stroke hydraulic system with automatic speed adjustment



MOBILE

2 steering wheels fitted with a brake, 2 castors



ERGONOMIC

the suitable working height can always be selected between 450 - 1,100mm



STURDY

solid steel structure, powder-coated surfaces



FLEXIBLE

depending on the application, with optional extensions, with adjustable size



For worktops, refer to page 13

Lifting table H 850 with optional worktop



USER VIDEO
www.barth.tv



High-quality castors
smooth-running, 2x with brake and 2x fixed castors **01**

Solid, torsion-resistant base structure
height adjustable: 450–1,000mm **03**

Comfort
The foot pump chooses automatically the right step:
1. step: Quick lift for small loads
2nd step: Easy lift for loads up to 600 kg or 850 kg **02**

Sturdy scissors-type structure
for uniform load holding **04**

Optional worktop or hole plate
2,000x1,015x30 mm. With longitudinal pull-outs of 550mm on both sides available. Accessories for hole plate, refer to page 21 **05**

Electrical hydraulics for comfort

Lifting table H 1000 accuDRIVE / eDRIVE



Lifting table H 1000 accuDRIVE

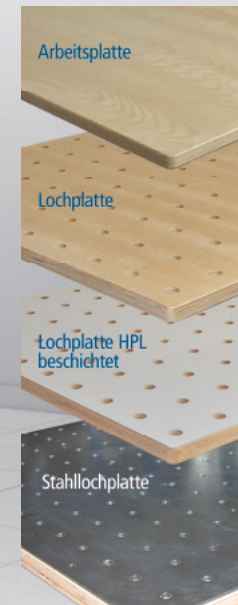

For worktops, refer to page 13

Base version lifting table H 1000

- > accuDRIVE with 12V hydraulic unit
- > eDRIVE with 230V hydraulic unit
- > Operation by foot switch
- > Load capacity 1,000 kg
- > 2 steering rollers with brake
- > 2 castors
- > Bellow
- > Optional worktop
- > Lx WxH: 2,000 x 1,015 x 450- 1,100 mm

High-quality castors
smooth-running, 2x with brake
and 2x fixed castors **01**

Solid, torsion-resistant
base structure **03**
height adjustable: 450–1,000 mm

Remote control (optional) **05**

Lockable main switch **02**

Sturdy scissors-type structure **04**
for uniform load holding

(Optional) worktop or hole plate **06**
2,000x1,015x30 mm. With longitudinal
pull-outs of 550mm on both sides available.
Accessories for hole plate, refer to page 21

Accessories for lifting tables

Longitudinal pull-out 550 mm



On both sides, suitable for	Art.no.	On both sides, suitable for	Art.no.
hole plate H350 XL	BH-26-44	lifting table H 600 / H 850 / H 1000	BH-35-45
vakuuLIFT-S / H 350 XL	BH-26-43	HPL hole plate H 600 / H 850 / H 1000	BH-35-46
HPL hole plate vakuuLIFT-S	BH-12-44		

Pull-out rails



	Art.no.
set of 2 pcs 350 XL / vakuuLIFT-S, H 600 - H 1000, length 1,150mm	BH-16-93
lifting table H 300 + VakuuCar®, length 940 mm	BH-17-92

Substructure



NEW

	Art.no.
substructure with stacker holders H 600 / H 850 / H 1000	BH-35-34

Drawer attachment



NEW

	Art.no.
drawer attachment H 350 XL / H 600 / H 850 / H 1000	BH-26-42

Lifting table worktops



Worktop birch-multiplex single-layer coated	Art.no.
H 300 - 1,245 x 740 x 24 mm (included in the base version)	BH-17-68
H 350 XL- 2,000 x 1,015 x 24 mm (included in the base version)	BH-30-21-2010
H 600 / H 850 / H 1000 2,000 x 1,015 x 30 mm	BH-10-88



Hole plate birch-multiplex, hole grid 100 mm, hole diameter 22 mm	Art.no.
H 300 - 1,500 x 800 x 30 mm	BH-17-70
H 350 XL / H 600 / H 850 / H 1000 2,000 x 1,015 x 30 mm	BH-30-24-2010

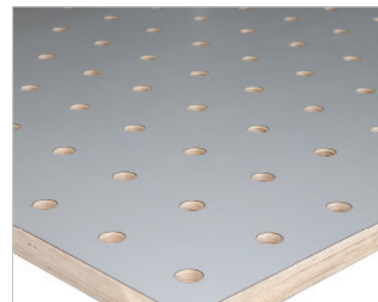

Hole plate HPL coated birch-multiplex, hole grid 100 mm, hole diameter 22 mm	Art.no.
1,500 x 800 x 30 mm	BH-17-74
H 350 XL 2,000 x 1,015 x 30 mm	BH-30-29-2010

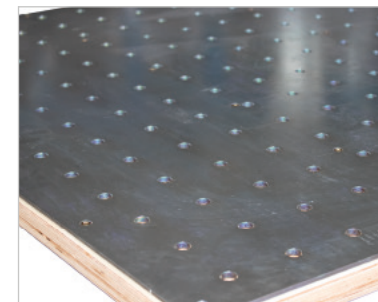

Steel hole plate 6mm on birch multiplex 30mm, hole grid 100mm; hole diameter 15.5mm	Art.no.
H 600 / H 850 / H 1000 2,000 x 1,015 x 36 mm	BH-30-28-2010



NEW

Stainless steel cover plate for worktops	Art.no.
H 350 XL / H 600 / H 850 / H 1000 2,007 x 1,022 x 2.5 mm	BH-00-0147-01

Safe clamping in seconds: BARTH vacuum suction cups!

- > Reliable and safe clamping
- > Clamping in seconds by positioning the workpiece
- > Releasing by foot switch
- > Protecting sensitive surfaces
- > Clamping without any marks and without any silicone residues

Mobile to follow the work - BARTH work tables are mobile! They follow the workpieces to any place in the workshop.



Instant information:
☎ +49 8634 9827 0
✉ info@barth-maschinenbau.de

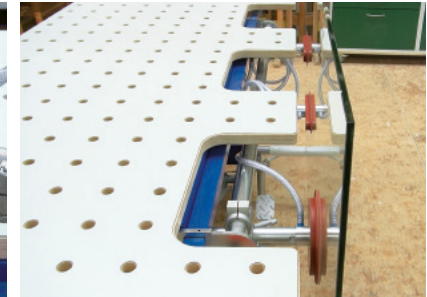
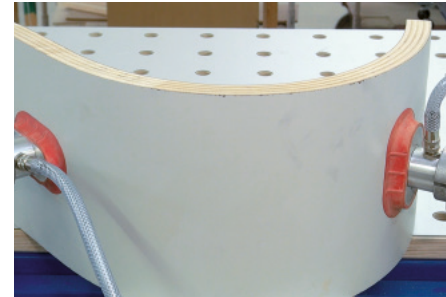

The vakuuSYST® is an ergonomic makeover for your bench.

vakuuSYST® can simply be screwed under the bench and, as need be, be brought to its working position with only one move of the hand. Equipped with a height- and tilt-adjustable vacuum suction cup, the vakuuSYST® clamps the workpiece in seconds and fixes it securely in the optimal working position. Just place the workpiece on the vacuum suction cup and it's clamped as, when placing the workpiece, the pushbutton valve specially developed by BARTH for everyday use in woodworking operations automatically enables the suction cup. Processing may begin immediately at optimum working position. Pressing the foot switch releases the vacuum.

Your workbench starts its career

VakuuSYST® 3.15 SET



Space-saving, folded down below the bench.

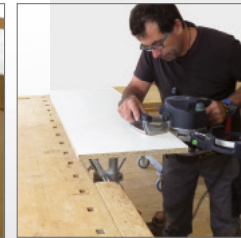
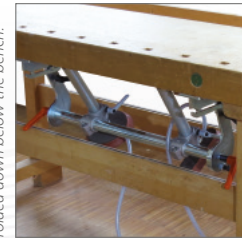

45° position

VakuuSYST® 180

Flexibly clamped to any worktop. Also perfect on site.



Base version VakuuSYST 180

- > El. vacuum pump 230 V
- > 1 flat vacuum suction cup, round 190 mm
- > Manual slide valve
- > Joint 180°
- > Table clamping for worktops up to 50 mm

Base version vakuuSYST® 3.15 SET

- > 1 electrical vacuum pump with dust filter
- > 1 solid support for assembly to an existing bench
- > Required length between collets 940 mm
- > 1 flat vacuum suction cup Ø approx. 190 mm 1 vacuum suction cup 250 x 80 mm installed on pivotable axis
- > Foot valve

- 01 Bracket with rotary axis
0 - 90° pivotable
- 02 Vacuum pump
- 03 Foot valve
- 04 Flat vacuum suction cup

vakuuSYST 3.15 SET



USER VIDEO
www.barth.tv



The workpiece profile – perfect for paint preparation

VakuuCar®+

- 
SILICONE-FREE
 vacuum suction cups for powerful clamping of the workpiece without any marks
- 
MOBILE
 freely usable due to the smooth-running movable frame
- 
QUALITY
 powder-coated steel parts, dry-running vacuum pump
- 
PIVOTABLE
 pivotable rotary axis (90°) for horizontal and vertical clamping

Base version VakuuCar®+ easyMOTION

- > Vacuum pump for continuous operation (performance: 3 m³/h)
- > Foot valve for releasing the clamped workpieces
- > Base frame with 90° rotary axis for vacuum suction cups
- > 2 flat vacuum suction cups: 1 x 190 mm round, 1 x 250x80 mm with quick-change system
- > Pull-outs +450 mm on both sides
- > 5 support bars with squared timber to pull out
- > Integrated socket strip for auxiliary equipment
- > easyMOTION height adjustment with manual crank
- > In 6 positions adjustable bench dogs as support
- > Footprint L x W x H: 1,350x800x850 or 2,100x1,400x1,050 mm

Additional accessories refer to page 20

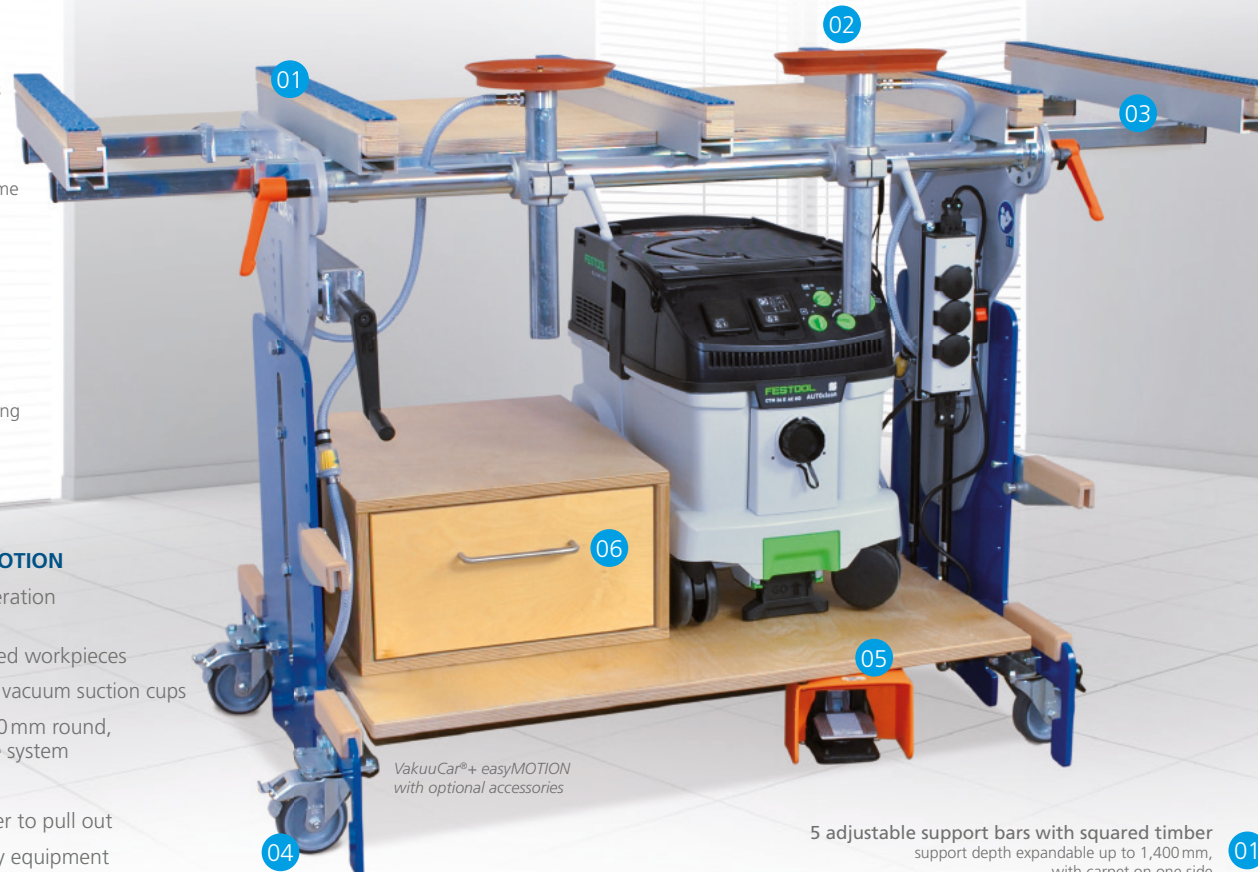

VakuuCar®+ easyMOTION
with optional accessories

- 5 adjustable support bars with squared timber support depth expandable up to 1,400 mm, with carpet on one side **01**
- 2 flat vacuum suction cups with extra soft and flexible sealing lips, gentle on the workpiece and silicone-free, with quick-change system **02**
- Pull-outs on both sides each side +450 mm **03**



USER VIDEO
www.barth.tv



- High-quality castors smooth-running, 2x with brake and 2x with direction lock **04**
- Vacuum pump powerful electrical vacuum pump 120W with dust filter and foot valve **05**
- Space plenty of space for tools, vacuum cleaner or optional drawers (accessories on page 20) **06**

The mobile work and assembly table VakuuCar® XL



FLEXIBLE

vacuum cups in different sizes allow the clamping of the most different form



ERGONOMIC

height-adjustable worktop on base unit and vacuum cups



TIME-SAVING

efficient work processes save time

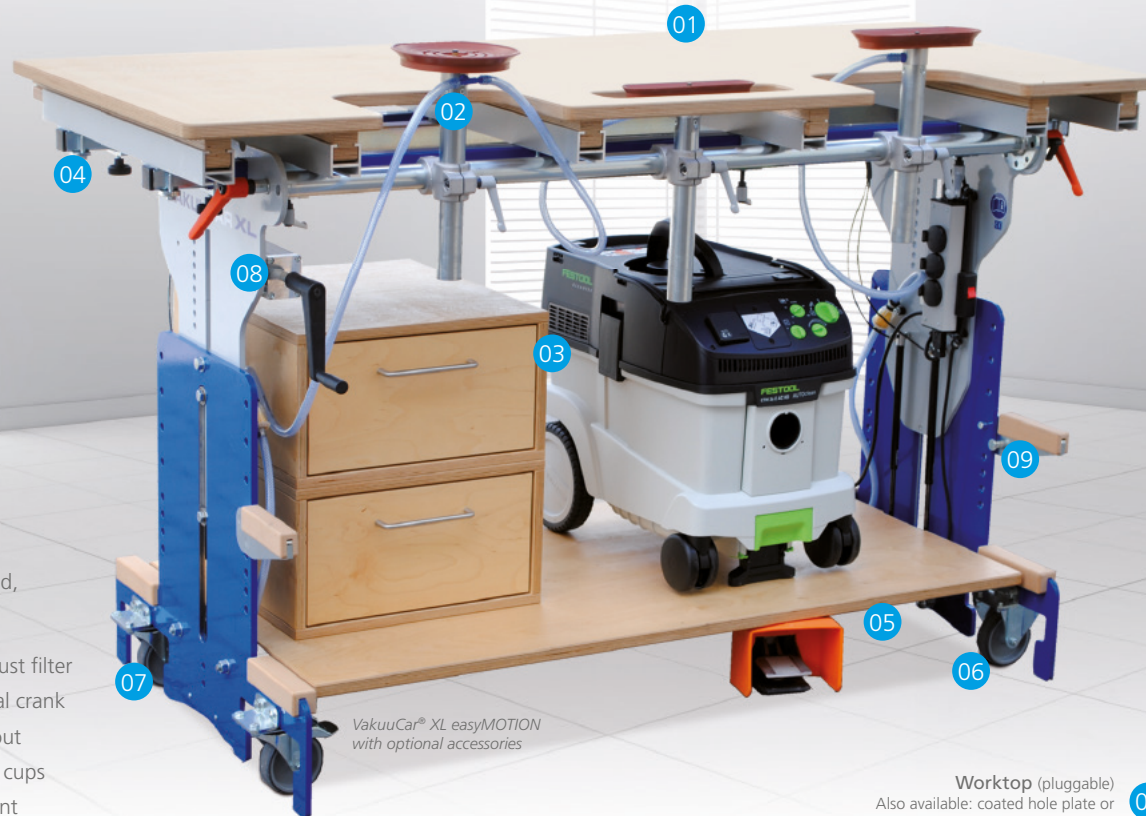

VakuuCar® XL easyMOTION
with optional accessories

Base version VakuuCar®XL easyMOTION

- > Base frame with 90° rotary axis for vacuum suction cups
- > 3 flat vacuum suction cups: 1x 190 mm round, 1x 250x80 mm, 1x 240x45 mm with quick-change system
- > Vacuum pump 120W, 230V, 3 m³/h, with dust filter
- > easyMOTION height adjustment with manual crank
- > 4 support bars with squared timber to pull out
- > Worktop with 3 cutouts for vacuum suction cups
- > Integrated socket strip for auxiliary equipment
- > In 6 positions adjustable bench dogs as support
- > Footprint Lx WxH: 1,800 x 800 x 874 – 1074 mm

Also available with hole plate 2,000x800x30mm (refer to accessories on page 20)



USER VIDEO
www.barth.tv



Worktop (pluggable)
Also available: coated hole plate or suction hole plate with suction connection



3 flat vacuum suction cups
with extra soft and flexible sealing lips, gentle on the workpiece and silicone-free, with quick-change system



Container with 2 drawers
(optional, refer to accessories page 20)



Longitudinal pull-out
(optional)



Vacuum pump
powerful electrical vacuum pump 120W with dust filter and foot valve



High-quality castors
smooth-running, 2x with brake and 2x with direction lock









The perfect assembly table for flexible applications vakuuLIFT-S

Equipped with 3 flat vacuum suction cups, the vakuuLIFT-S assembly table is an ergonomically optimal work and assembly table for maximum loads.

Each flat suction cup is individually height-adjustable and pivotable by 90°. Height-adjustment is performed by a smooth-running hydraulic foot pump, switching automatically between quick and lifting stroke. The smooth-running high-quality rollers provide maximum mobility.



- 
SILICONE-FREE
silicone-free suction cups for clamping without any marks
- 
MOBILE
mobile and flexible use for customized applications
- 
ERGONOMIC
flexible work height due to height adjustment on the base unit and on the suction cups
- 
PIVOTABLE
pivotable rotary axis (90°) for horizontal and vertical clamping
- 
FLEXIBLE
different sizes of suction cups can be fitted
- 
UNIVERSAL USE
the worktop can be extended to a surface of 7 m² with the optional longitudinal pull-out and pull-out rails



vakuuLIFT-S with optional longitudinal pull-out



The hole plate can be used for pressing and assembly

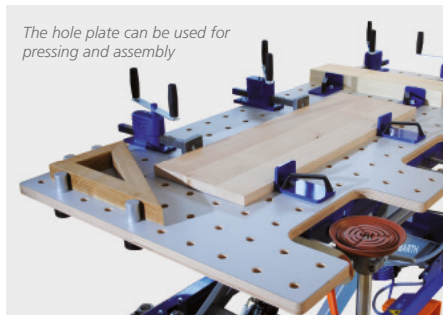

Work table vakuuLIFT-S SET

(BH-31-06) in addition to base version:

- › HPL hole plate
- › Longitudinal pull-outs (on each side 550 mm)

Base version vakuuLIFT-S

- › Base: Lifting table 350 XL
- › 3 vacuum suction cups with quick coupling: 190 mm round, 250x80mm, 240x45 mm
- › Vacuum pump 230V, 3 m³/h
- › Outlet strip
- › Foot pedal on both longitudinal sides
- › Support
- › Multiplex worktop 2,000x1,015 mm
- › Footprint Lx WxH: 2,000 x 1,060 x 550 – 1,150 mm

Variant eDRIVE (230 V)

- › Max. load 250 kg, max. height 1,120 mm

Accessories, refer to pages 21 and 22



„The bench area optimization that we carried out with BARTH started with the first vakuuLIFT about 3 years ago. Before that, we made experiments with simple lifting tables. But then we came to the conclusion that only the full version with vacuum clamping device and accessory program made sense for us. This solution convinced us and, meanwhile we have equipped all manual workstations with the vakuuLIFT.

Berhard Daxenberger,
managing director of
Schreinerei Daxenberger
in Seon

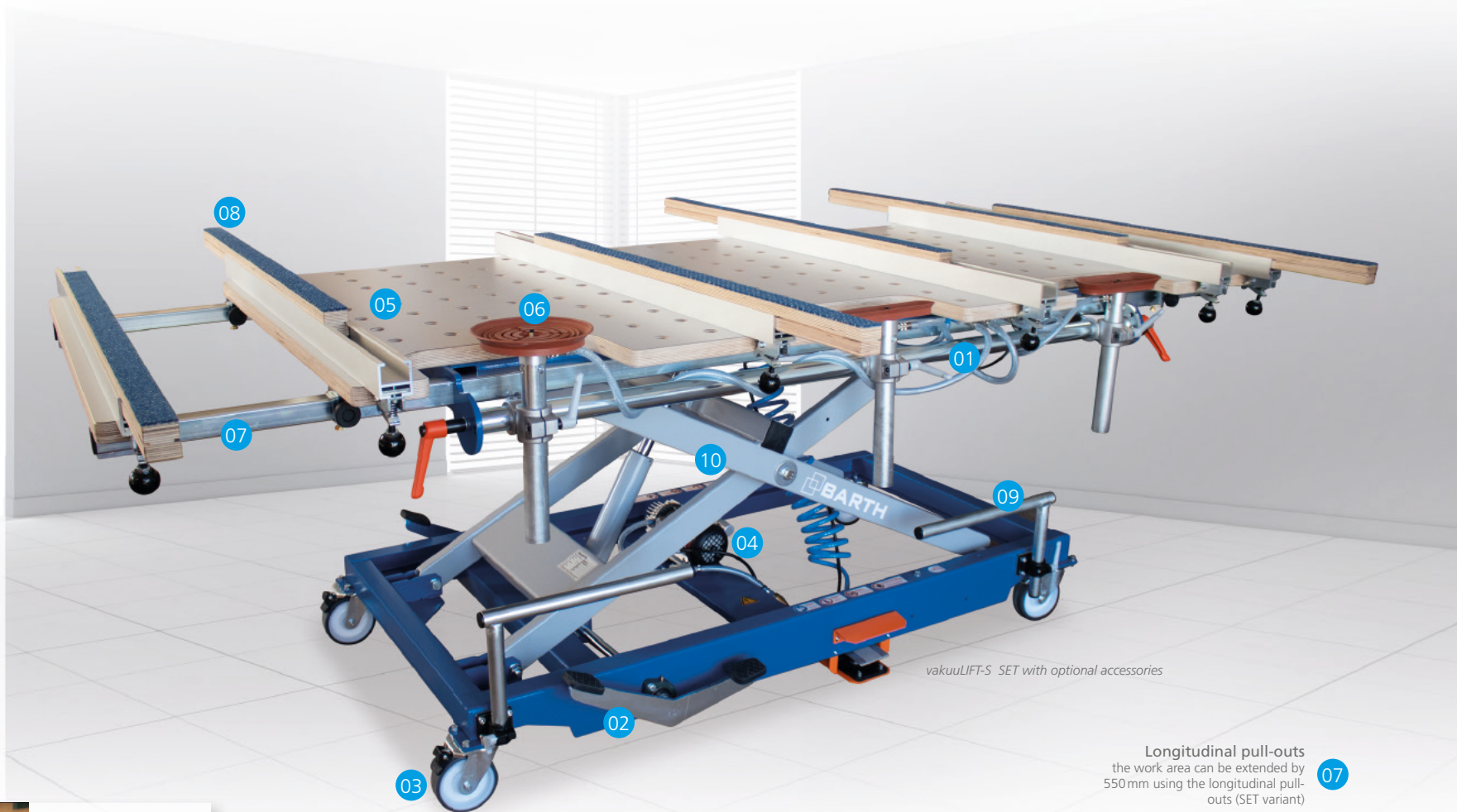

vakuuLIFT-S SET with optional accessories



USER VIDEO
www.barth.tv



- 01** Integrated vacuum rotary axis for progressive clamping of workpieces (0° - 90°)
- 02** Foot-pumped hydraulic system on both sides, operable on both longitudinal sides with overload protection
- 03** High-quality castors smooth-running, 2x with brake and 2x with direction lock
- 04** Vacuum pump powerful electrical vacuum pump 120 W with dust filter and foot valve
- 05** Perforated worktop worktop 2.000 x 1.015 mm HPL coated (SET variant)
- 06** 3 flat vacuum suction cups with extra soft and flexible sealing lips, gentle on the workpiece and silicone-free, with quick-change system
- 07** Longitudinal pull-outs the work area can be extended by 550mm using the longitudinal pull-outs (SET variant)
- 08** Pull-out rails the optional pull-out rails can be used to extend the worktop by 550mm in width with each rail
- 09** Support heavy workpieces can be placed on the adjustable tray angles.
- 10** Sturdy base structure scissors made of solid square tubes Adjustment range: 550–1,150mm

Accessories for VakuuCar®

Container with 2 drawers



Art. no. BV-08-81

size 460x450x500 mm
Full pull-out

Drawer



Art. no. BV-08-74

size 250x450x500 mm
Full pull-out

Lateral support



Art. no. BV-32-36

size 410x320 mm

Pull-out rail 940 mm



Art. no. BH-17-92

pull-out rail for VakuuCar® and
lifting table 300; worktop 24 mm; length
940 mm

Automatic cutout for
vacuum pump with tank.

Art. no. BV-32-35

Hole plate

VakuuCar®XL



Art. no. BV-15-69

worktop with milled grooves
for VakuuCar®XL (1,800x740x24 mm)

Longitudinal pull-out

VakuuCar®XL

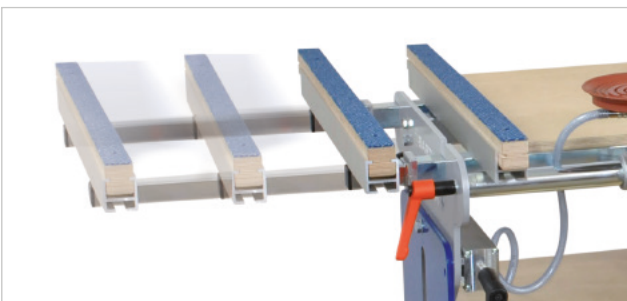

Art. no. BV-33-34

extension on both sides 450 mm
(included in the VakuuCar®+ base version)

Suction hole plate

for VakuuCar®XL



Art. no. BV-33-35

suction tube connection 160 mm
wood dust tested according to DGUV

Accessories for wooden hole plate with 22 mm holes

Counter-bearing 360°

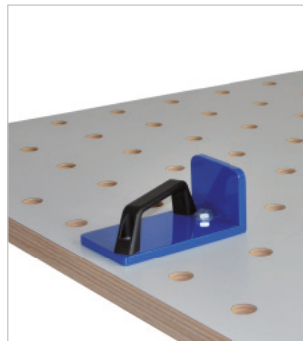

	Art.no.
360° pivotable, height 70mm	BH-12-34
for steel hole plate	BM-70-34

Push rod clamping device



Art. no. BH-12-37
spring-loaded, clamping force approx. 250 kg

Push rod clamping device

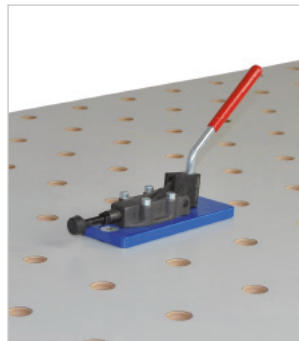

Art. no. BH-12-36
clamping force approx. 500 kg

Wooden strip with carpet

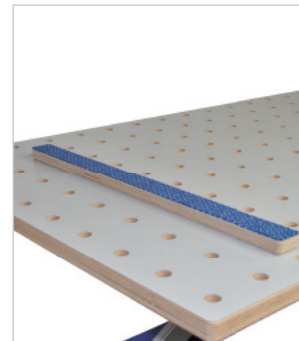

Art. no. BH-10-79
pluggable Length 750mm

Rack-and-pinion gear

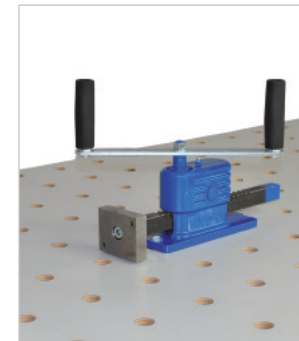

	Art.no.
clamping force approx. 1,000 kg, 155 mm stroke	BH-12-33
for steel hole plate	BH-12-52

Adapter sleeve

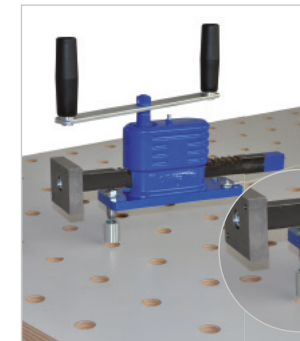

Art. no. BH-12-38
for wooden hole plate: With this adapter sleeve, the pressure elements of the steel hole plate with small bolts can be used on the wooden hole plate with large holes.

Rack-and-pinion gear, small



	Art.no.
150mm stroke clamping force 200 kg	BH-12-47
for steel hole plate	BH-12-51

Bumping stop

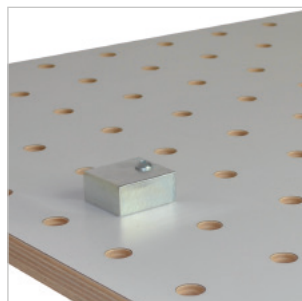

	Art.no.
L x W x H: 70 x 60 x 30 mm	BH-30-34

Vertical clamping device



	Art.no.
with 2K handle jaw capacity 100mm clamping height 200mm	BH-12-31
for steel hole plate	BM-70-39

PACKAGE OF ACCESSORIES WOODEN HOLE PLATE

3x rack-and-pinion gear small,
4x stop block, 2x vertical clamping device,
Art. no. BH-12-35

Accessories and vacuum suction cups

Accessories for rotary axis and pull-out rail

3D bracket



Art. no. BV-08-68

3D-holder for vacuum suction cups for mounting in the pull-out rail

Vice



Art.no.

with holding tube, without cross clamp
clamping range 100 mm
jaw width 100 mm
Clamping range 90 mm

BV-08-77

vice package for APS-ORGA II

BV-61-40

Extension

(with cross clamp)



Art. no. BV-08-57

length 400 mm

Hose extension

Art. no. BV-23-98-20

hose extension 2 m incl. quick coupling

Automatic cut-out for vacuum pump with tank

Suitable for	Art.no.
VakuuCar®+ / XL	BV-32-35
vakuuLIFT-S	BH-16-35

Silicone-free suction cups

The efficient suction cups from BARTH have a large and solid support surface and have been designed for all materials in wood processing.

Equipped with the sophisticated BARTH pushbutton valve, they react very sensitively to all workpieces. High-gloss lacquered surfaces are clamped by the suction cups without leaving any marks

Suction cup 11.7



Art. no. BV-23-110065

size 110x65 mm
incl. pushbutton valve, holding tube and quick coupling connection

Suction cup 24.5



Art. no. BV-23-240045

size 240x45 mm
incl. pushbutton valve, holding tube and quick coupling connection

Suction cup 25.8



Art. no. BV-23-250080

(included in the base version)
size 250x80 mm
incl. pushbutton valve, holding tube and quick coupling connection

Suction cup 30.3



Art. no. BV-23-300030

size 300x30 mm
incl. pushbutton valve, holding tube and quick coupling connection

Round suction cups



Art. no. BV-23-190

(included in the base version)
size Ø 190 mm incl. pushbutton valve, holding tube and quick coupling connection

Ideal supplement for vakuuLIFT-S or VakuuCAR® orgaCAR

Base version orgaCAR

Solid drawers with full pull-out,
vacuum cleaner container, pressure
element holder, triple electrical socket
strip and boom with
 > 1 energy module with shock-proof
socket and compressed air supply
 > 2 sliders with eyelet

Also available without drawer
insert

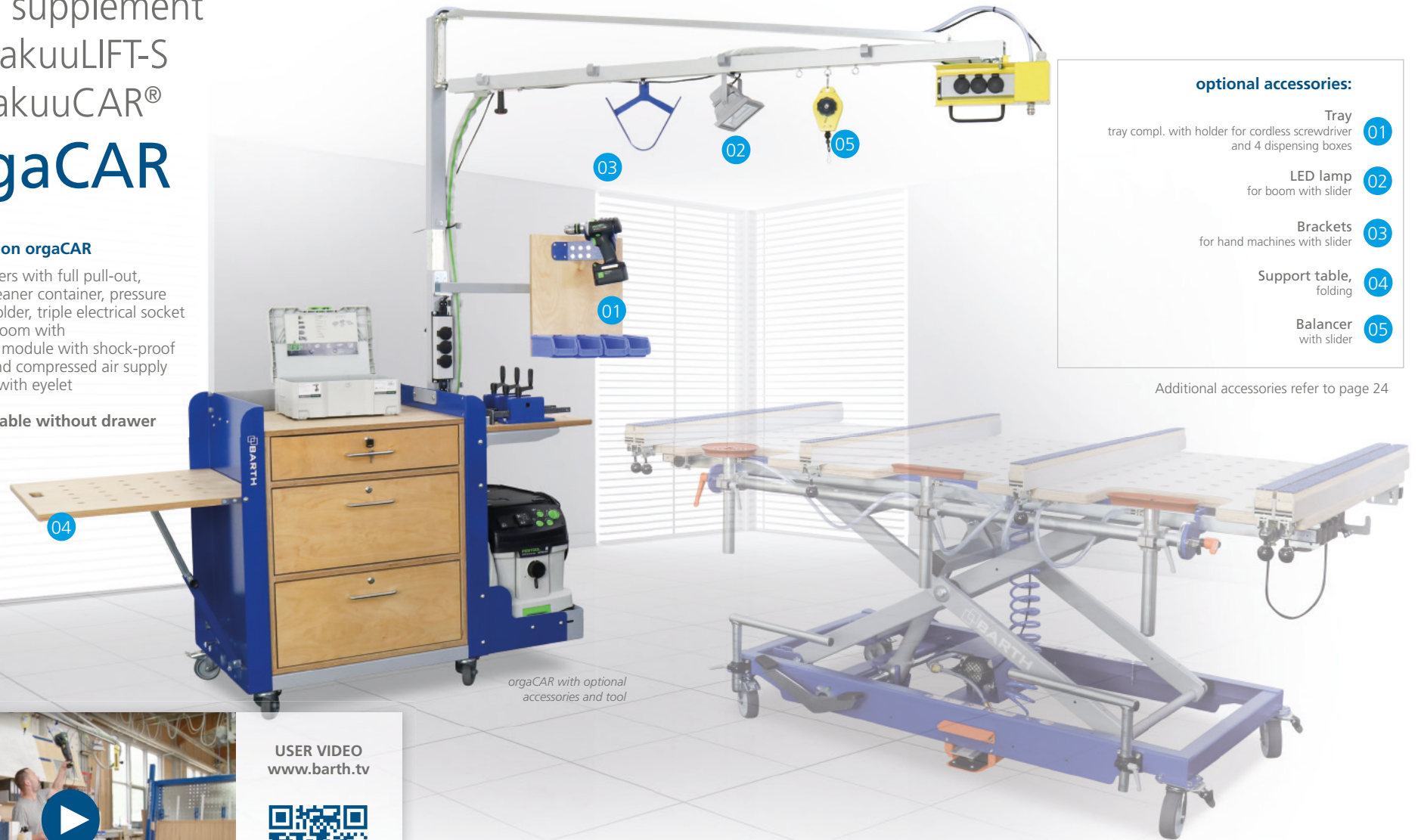

orgaCAR with optional
accessories and tool

optional accessories:

- Tray
tray compl. with holder for cordless screwdriver
and 4 dispensing boxes **01**
- LED lamp
for boom with slider **02**
- Brackets
for hand machines with slider **03**
- Support table,
folding **04**
- Balancer
with slider **05**

Additional accessories refer to page 24



USER VIDEO
www.barth.tv



Accessories for APS-ORGA II

Locker



Art. No. BV-61-00-60

for back panel

Back panel package



Art. No. BV-61-43 (without wooden parts)

Tray



Art. no. BV-61-33

with holder for cordless screwdriver
and 4 dispensing boxes

Front plier



Art. no. BV-61-41

Accessories for orgaCAR

Folding table



Art. no. BV-65-42

with perforated worktop

Balancer



Art. no. BV-65-40

Bracket



Art. no. BV-65-35

for manual machines

LED lamp



Art. no. BV-65-41

Ergonomics individually organised

APS-ORGA II



TIME-SAVING

due to optimum organisation at the workplace



QUALITY

base frame made of solid steel, powder-coated surface



FLEXIBLE

with movable lifting table

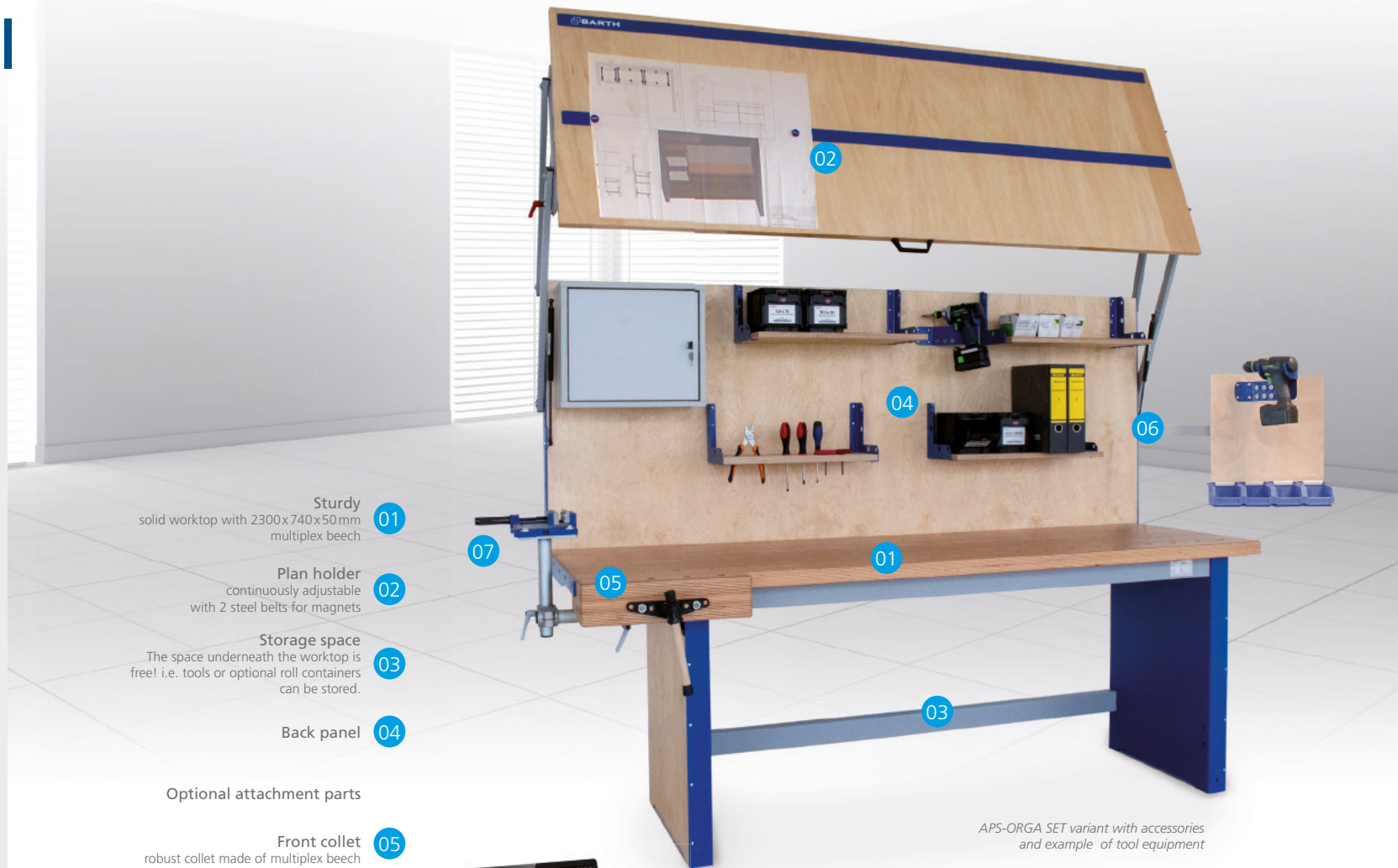

01 **Sturdy**
solid worktop with 2300x740x50 mm
multiplex beech

02 **Plan holder**
continuously adjustable
with 2 steel belts for magnets

03 **Storage space**
The space underneath the worktop is
free! i.e. tools or optional roll containers
can be stored.

04 **Back panel**

Optional attachment parts

05 **Front collet**
robust collet made of multiplex beech

06 **Tray**
pivotable with holder for cordless screwdriver

07 **Vice**

APS-ORGA SET variant with accessories and example of tool equipment

Base version
APS- ORGA II

- > Base frame
- > Back panel not equipped
- > Plan holder



Instant information:
☎ +49 8634 9827 0
✉ info@barth-maschinenbau.de

Additional accessories refer to page 24

Heavy doors easily turned wendoSYST

Large, heavy workpieces such as front doors or panel elements can be clamped and turned by 180°.

The stable base structure is mobile and can therefore be used throughout the entire plant. The pull-out frame cross-connection is attached to the rear. This design offers the great benefit that the assembly of large, heavy elements can be done by an employee, using a lifting table (e.g. lifting table 300).

Automatic surface clamping with opening on both side is optional.



The wendoSYST can be equipped with a lifting table.



ERGONOMIC

adjustable height for user or workpiece



MOBILE

mobile with 4 sturdy steering rollers with brake



STURDY

workpieces up to 200kg can be turned



FLEXIBEL

adapts easily to door and workpiece lengths Length 1,190 - 2,504mm

Base version wendoSYST

Mobile turning device for large and heavy workpieces such as front doors. Adaptable to door and workpiece lengths, can be equipped with lifting table 300

- > Base frame with support bracket and spindle clamping
- > Engaging head, mobile with quick adjustment
- > Workpiece clamping dimensions (Lx W): 1,190–2,504 x 30–1,700 mm
- > Thickness of workpiece: 23–112 mm
- > Height of rotary axis: 752–1,064 mm (adjustable with spring bolt)
- > Working height adjustable by 312 mm
- > Standing depth expandable by 250 mm
- > Mobile with 4 steering rollers Ø 125 mm, each equipped with a brake
- > Loadable up to max. 200 kg
- > Footprint Lx W: 2,220–3,300 x 860–1,110 mm



Stud engaging device optional (BH-40-38)



Stud engaging device for doors, opening on 2 sides, optional (BH-40-39)



Variant with surface clamping with opening on both sides (BH-40-06)



"Among other things, we produce heavy room and front doors. Right from the start, our heavy doors are mobile either using the lifting table or the turning device. We use the device for sanding, mortising and when mounting seals and hinges. Using the stud engaging device, the door can be lacquered or oiled in the wendoSYST. The wendoSYST is meanwhile an irreplaceable tool for us, especially in connection with the lifting table 300."

Carpentry Albert Bartlechner GmbH, Halsbach



Instant information:
 ☎ +49 8634 9827 0
 info@barth-maschinenbau.de

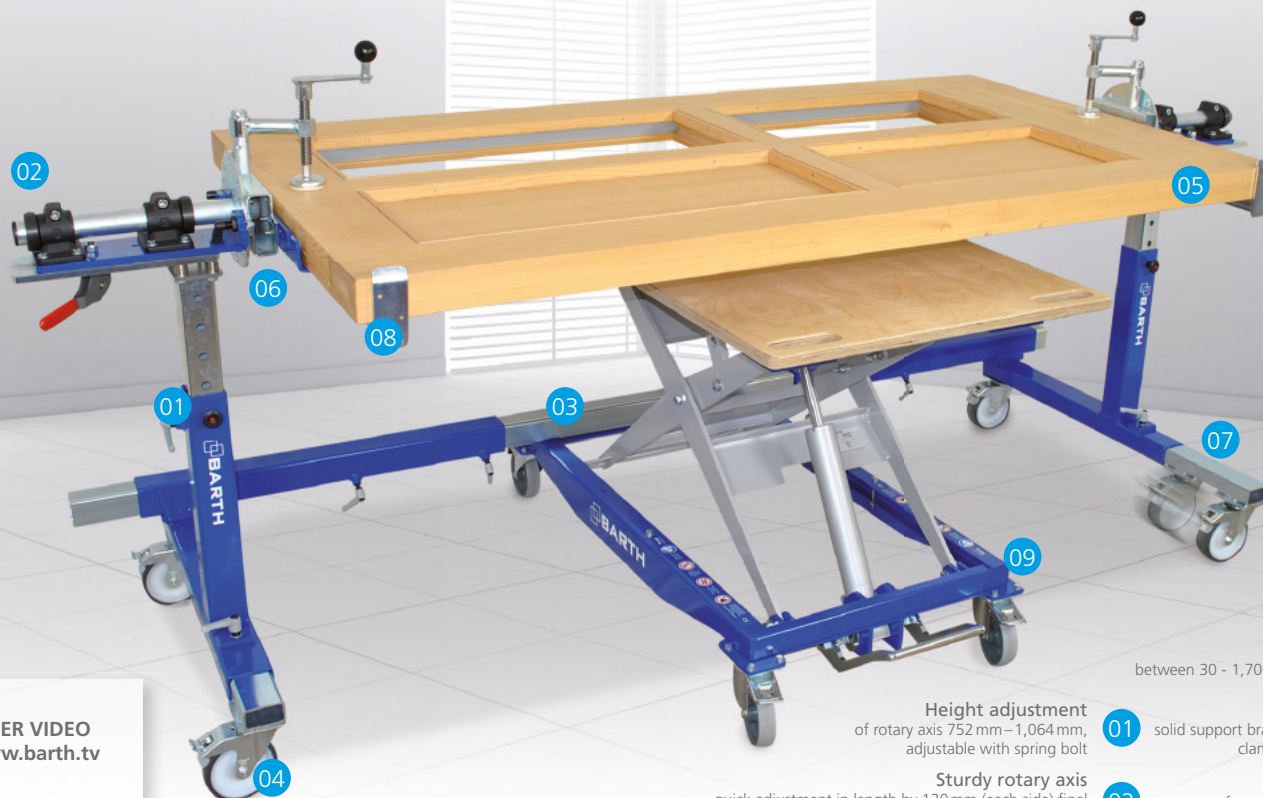

USER VIDEO
www.barth.tv



- 01 **Height adjustment**
of rotary axis 752 mm – 1,064 mm, adjustable with spring bolt
- 02 **Sturdy rotary axis**
quick adjustment in length by 120 mm (each side) final stops at 0° and 180°, intervals of 45°
- 03 **Longitudinal adjustment**
using solid square tubes and clamping with clamping lever between 1,190 - 2,504 mm
- 04 **Versatile**
4 high-quality and sturdy steering rollers, equipped with a brake
- 05 **Large workpieces**
between 30 - 1,700 mm, can be turned in width
- 06 **Support**
solid support bracket with trapezoidal spindle clamping (can be swivelled away)
- 07 **Stable**
for very large workpieces, the front wheel can be pulled out.
- 08 **Safety**
2 adjustable safety strips
- 09 **Perfect with lifting table 300**
can be equipped (refer to page 6)

The height-adjustable work table with turning device wendoLIFT II

The BARTH wendoLIFT II turning device has one integrated turning device for heavy workpieces.

The wendoLIFT II can be used as turning device and as work table.



The height-adjustable work table with turning device for heavy workpieces.

- > Ergonomic working height
- > Efficient work processes save time
- > Large lifting range 500 - 1,150 mm
- > Energy-saving turning of heavy workpieces up to 140 kg
- > Sturdy steel structure
- > With powerful battery drive unit 88A (incl. charger)

How turning works



Can be used as work table.

Base version wendoLIFT II accuDRIVE

- > 12V hydraulic unit
- > Incl. remote control
- > 2 castors
- > 2 steering rollers with brake
- > Multiplex plate with carpet
- > Table extensions with carpet on both sides
- > 12V charger
- > Load capacity as turning device 140 kg
- > Max. workpiece width for turning 1,300 mm
- > Footprint Lx WxH: 1,800 x 1,160 x 500- 1,150 mm

Variant wendoLIFT II eDRIVE:

- > 230V hydraulic unit



ERGONOMIC
controlled by remote control



ECONOMICAL
turn doors up to 140 kg without the need of a second person



QUALITY
sturdy steel structure with accu unit



MOBILE
mobile and flexible use for customized applications



FLEXIBLE
can be used as work table, folding function can be removed



wendoLIFT II accuDRIVE with optional accessories



USER VIDEO
www.barth.tv



- Remote control with magnetic holder 01
- Table extension 02
- Supports optional 03
- Steering roller with brake 04
- Worktop with carpet 05
- Battery disconnection switch 06
- Detachble turning supports 07

Work table with integrated turning device for processing large workpieces

wendoLIFT RL



Rollers in extended condition

As with the classic wendoLIFT, the H 1000 accuDRIVE lifting table is the basis of the wendoLIFT RL. **The pneumatically activated roller tracks** make the table even more comfortable and efficient. This not only makes it easier to load via feeding roller tracks but also to position heavy workpieces on the table. The roller tracks are arranged crossways to the folding wings and can be activated via a pneumatic valve on the control unit. This means that the tracks are pressed upwards via the compressed air and, are thus above the supporting surface. As an option, we can also offer the tracks arranged lengthways. So, it is possible to move the workpieces in 2 directions.

The turning function of the wendoLIFT RL allows to turn workpieces up to a weight of 140 kg and a width of 130 cm.



How turning works

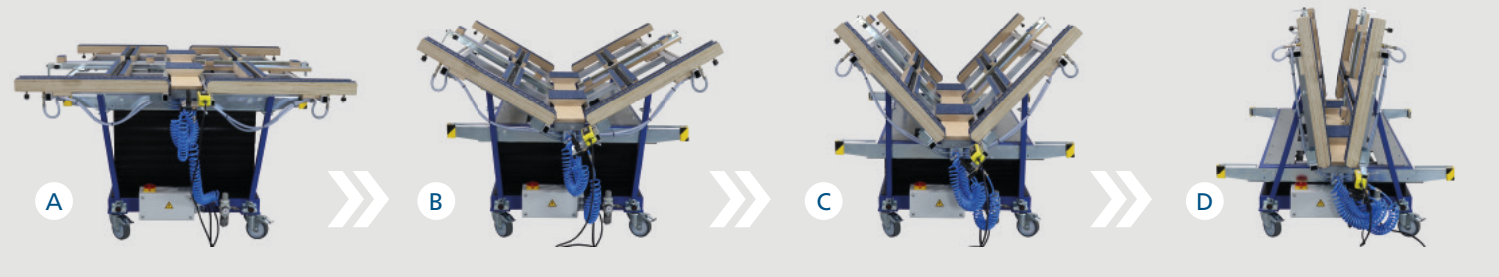

Base version wendoLIFT RL eDRIVE

- > 230 V hydraulic unit
- > Incl. remote control
- > 4 pneumatically controlled, lowerable roller tracks
- > Load capacity as turning device 140 kg
- > Max. workpiece width for turning 1,300 mm
- > Footprint L x W x H: 2,000 x 1,160 x 500 - 1,150 mm
- > Optional moving device
- > Optionally available with additional longitudinal roller tracks

Variant wendoLIFT II accuDRIVE:

- > 12 V hydraulic unit



ERGONOMIC

controlled by remote control



QUALITY

sturdy steel structure with accu unit



FLEXIBLE

can be used as work table, folding function can be removed



TIME-SAVING

due to optimum organisation at the workplace



wendoLIFT RL with optional additional equipment



USER VIDEO
www.barth.tv



Longitudinal roller track optional 01

End stop turned away 02

Transverse roller track 03

Steering roller with brake 04

Roller track control 05

Control unit with removable cable remote control, extendable 06

End stop for rolling workpieces, turnable 07

Easy loading and unloading of long and bulky parts.

kipplIFT

The work table "kipplIFT" facilitates the transport of long, heavy and bulky parts such as doors, kitchen counters, panel material, by easy loading and unloading.

The base structure of the "Lift Table 300 XL" remains the same with all its benefits - a smooth-running chassis for easy handling, a pedal system operated lifting system with 300 kg load capacity and the individually adjustable working height between 740 - 1,300 mm - and is extended by a smooth-running tilting system. This makes it possible to pivot the worktop of the table by 89° lengthwise. The powerful gas springs support the crank drive and allow workpieces to tilt effortlessly.

For long workpieces, a 555 mm long pull-out is provided on both sides. The wide stop angle provided on one side is used to easily hold the workpieces in the tilted state. This allows to move bulky workpieces from the vertical to the horizontal position without any help.



kipplIFT can also be used as work table



Base version kipplIFT

3 different variants are available!

Ask us.

- > 2 steering rollers with brake Ø 125 mm
- > 2 steering rollers with direction lock Ø 125 mm
- > Folding stop bar
- > Height adjustment on both longitudinal sides with foot pedals
- > Tilting function using a folding manual crank
- > 1x rigging strap for attaching the workpiece
- > Load capacity up to 300 kg
- > Longitudinal pull-out by 555 mm each
- > Large height adjustment range: 740–1,300 mm
- > Pivoting range 0–89°
- > Footprint Lx WxH:
2,240–3,350x 1,020x 740–1,300 mm





FLEXIBLE
use as feeding table for machines or as work and assembly table



ERGONOMIC
easy tilting of workpieces up to 4 m length



COMFORTABLE
height adjustment by foot pedal on both sides, tilting mechanism by manual crank



STURDY
powder-coated steel structure, sturdy tilting frame



Instant information:

+49 8634 9827 0
info@barth-maschinenbau.de



For worktops, refer to page 13



USER VIDEO
www.barth.tv



- Worktop 01
1,015 x 2,240 mm, can be extended to 1,015 x 3,350 mm by longitudinal pull-outs
- Sturdy scissors-type structure 02
for uniform load holding
- Foot-pumped hydraulic system 03
on both sides, operated on both longitudinal sides
- Sturdy base structure 04
powder-coated
- Stop bar 05
for easy unloading of workpieces

Do you have special requirements? Custom solutions of work tables



Special colours



Pneumatically driven lifting table



Custom small series

Overview of BARTH vacuum presses

TAURUS HP Page 36



TAURUS H Page 37



TAURUS Page 38

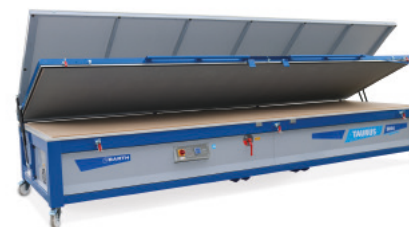

CORVUS Page 40



CORVUS-W Page 42



CORVUS-S Page 43



Faster curing time and more efficiency

The maximum performance of a vacuum pump lubricated with circulating oil is approx. 99 % of the ambient pressure. At an air pressure of e.g. 1,000 mbar, the achievable maximum pressure is 990 mbar. If this value is entered as the absolute switching point in a conventional pressure

switch, the pressure switch switches off the vacuum pump when this value is reached. If the air pressure changes, the switching point must be re-entered. If this is not done, it may occur that the pump is not switched off at lower pressure. At higher air pressure, however, the maximum possible pressure is not reached. The electronic

REVO II pressure switch from BARTH automatically calculates all necessary settings. Simply enter the desired relative value. E.g. set to 99% to get the maximum output of the pump. The setting is changed using the arrow keys. A second level shows all measured values clearly in the large display.

REVO II pressure switch

> Thanks to the new REVO II pressure switch, it is always possible to reach the maximum vacuum with a fluctuating air pressure.

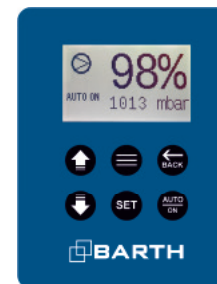

Speed-up option

- > Higher press of up to 10 t/m²*
- > Up to 50% shorter pressing times when veneering
- > Electronically maximised pressure
- > Electronic pressure monitoring with REVO II pressure switch

- > Digital vacuum display
 - > Continuous mode function with timer
 - > Vacuum pump 40 m³/h, lubricated with circulating oil
 - > Vacuum distributor plate
- * depending on the air pressure

The BARTH vacuum press TAURUS® HP: It combines flexibility in part processing and mass production with the widest possible work area. So, there is no limit to creativity and fields of application.

The industrial class TAURUS® HP

Industrial vacuum press TAURUS® HP with preheating station and parallel movement

Preheating station (H)

- > Max. size of workpieces: 2,650 x 950 mm
- > Electrical heating plate
- > Electronic temperature monitoring
- > Solid drawer slide
- > Connection: 400 V / 9,45 kW / 16 A

Parallel movement (P)

- > Large opening 1,370 mm (membrane frame bottom edge 1,950 mm)
- > 4 solid cylinders
- > Membrane removable frame (optional)

Base version TAURUS® HP / P

- > Membrane: Silicone membrane (HP), natural rubber, highly resilient (P)
- > **Standard version with speed-up:**
Pressure regulator: electronic, REVO II type, vacuum pump lubricated with circulating oil
Power: 40 m³/h, vacuum distributor plate
- > Tank capacity: 4 x 60 l (HP), 2 x 100 l (P)
- > Highly sturdy chassis
- > Additional vacuum connection with 13 mm hose fitting

- > Clamping dimensions L x W:
TAURUS® HP 3014 speed-up: 3,000 x 1,420 mm
 - > Footprint L x W x H:
TAURUS HP 3014 speed-up (with preheating station and parallel movement): 3,860 x 2,730 x 2,500 mm
TAURUS® P 3014 speed-up (with parallel movement) 3,860 x 1,540 x 2,500 mm
- Other sizes on request



The concept of the preheating station in the BARTH TAURUS H is based on an electric heating plate. This guarantees even and gentle heating of the materials without the risk of discolorations of the material.

Industrial vacuum press TAURUS® H with preheating station

Preheating station (H)

- > Max. size of workpieces: 2,650 x 950 mm
- > Electrical heating plate
- > Electronic temperature monitoring
- > Solid drawer slide
- > Connection: 400 V / 9,45 kW / 16 A

Base version TAURUS® H

- > Membrane: Silicone membrane, highly resilient
 - > **Standard version with speed-up:** Pressure regulator: electronic, REVO II type, vacuum pump lubricated with circulating oil
Power: 40 m³/h, vacuum distributor plate
 - > Tank capacity: 4 x 60 l
 - > Highly sturdy chassis
 - > Additional vacuum connection with 13 mm hose fitting
 - > Clamping dimensions L x W:
TAURUS® H 3014 speed-up: 3,000 x 1,420 mm
 - > Footprint L x W x H:
TAURUS® H 3014 speed-up (with preheating station): 3,860 x 2,730 x 940 mm
- Other sizes on request

The industrial class TAURUS® H



The industrial class TAURUS®

The BARTH TAURUS® vacuum press is the flagship of the vacuum press fleet. It combines flexibility in part processing and mass production with the widest possible work area. So, there is no limit to creativity and fields of application.

With lengths from 4 meters - up to special lengths - and the two **clamping depths of 142 and 182 cm**, the elasticity limits of the membrane are expanded in addition to the dimensions of the work table. Larger, higher and above all longer parts can thus be bonded in a comfortable way.

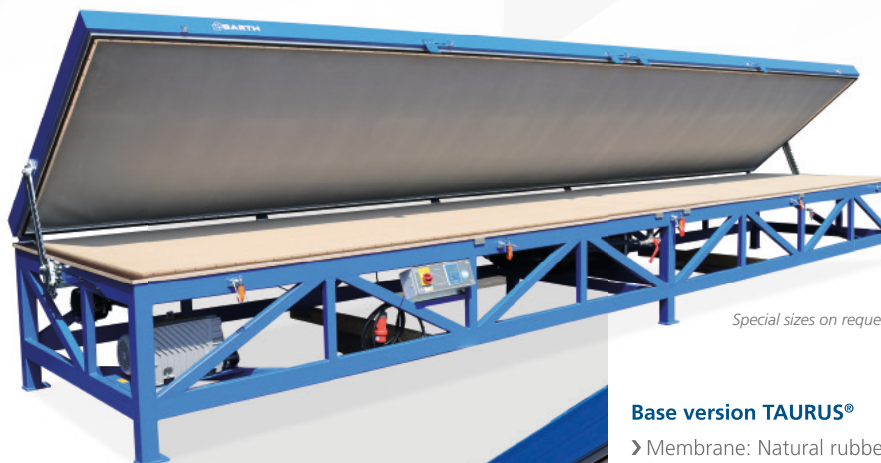





Special sizes on request



Latch for opening the membrane frame with overhead crane



-  **FLEXIBLE**
fields of application: Veneering, edge processing and shape bonding
-  **ENERGY-SAVING**
low energy consumption
-  **HIGH PRESSURE**
high pressure of up to 10t/m²
-  **STURDY**
solid welded structure
-  **EFFICIENT**
electronic pressure monitoring with REVO II pressure switch

Base version TAURUS®

- > Membrane: Natural rubber, highly resilient (silicone membrane upon request)
- > **Standard version with speed-up:**
Pressure regulator: electronic, REVO II type, vacuum pump lubricated with circulating oil
Power: 40 m³/h, vacuum distributor plate
- > Tank capacity: 2 x 100l
- > Highly sturdy chassis
- > Additional vacuum connection with 13 mm hose fitting
- > Clamping dimensions L x W:
TAURUS® 4014 speed-up or 5014 speed-up: 4,000 or 5,000 x 1,420 mm
TAURUS® 3018 speed-up, 4018 speed-up or 5018 speed-up: 3,000, 4,000 or 5,000 x 1,820 mm
- > Footprint L x W x H:
TAURUS® 4014 speed-up or 5014 speed-up: 4,290 or 5,290 x 1,650 x 940 mm
TAURUS® 3018 speed-up, 4018 speed-up or 5018 speed-up: 3,290, 4,290 or 5,290 x 2,050 x 940 mm

Clamping depths



TAURUS 5014 speed-up
with optional cover plate



USER VIDEO
www.barth.tv



Powerful vacuum pump 01
40 m³/h, mit 2 x 100 l storage tank

Sturdy base frame 02
welded and powder-coated

Differential pressure circuit 03
digital, REVO II

Movable frame 04
4 steering rollers with brake

Natural rubber membrane 05
highly resilient

Support for forklift 06

Vacuum connection 07
additional connection for vacuum bag

Cover plate, folding 08
protects the membrane against
sunlight (optional)

The vacuum press of the professional class

CORVUS®

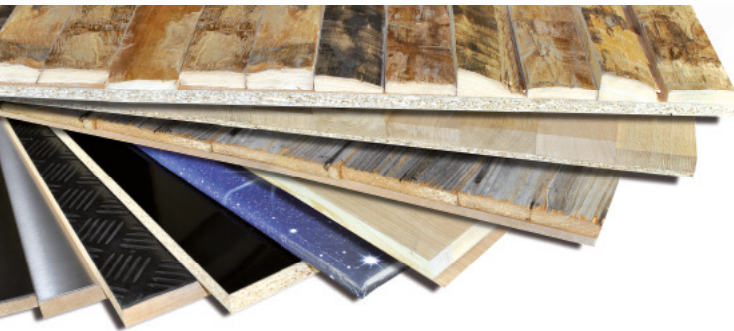

BARTH GmbH has launched a vacuum press in the professional class. The modern look is combined with a sturdy construction and offers ergonomic operation on the front side of the press.

Generally, the press is delivered in the mobile version. The CORVUS® incorporates the proven BARTH vacuum technology, which has been optimized further to achieve faster evacuation times. A 100l tank serves as a buffer so that it is not necessary to operate the vacuum pump in continuous mode. This guarantees a lower noise level and saves energy. A vacuum outlet for other applications such as a vacuum bag is also standard.

Optional

- > The speed-up option is available on request. The advantage of this option is the higher pressure and thus the shorter pressing time as well as the simple operation with the new REVO II pressure switch.
- > A second 100l tank can be ordered for even faster evacuation.
- > Another accessory is the cover plate protecting the membrane from sunlight and providing a large worktop.

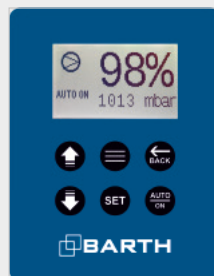

REVO II pressure switch

- > Thanks to the new REVO pressure switch, it is always possible to reach the maximum vacuum with a fluctuating air pressure.

speed-up option

- > Higher press of up to 10 t/m²*
- > Up to 50% shorter pressing times when veneering
- > Electronically maximised pressure
- > Electronic pressure monitoring with REVO II pressure switch
- > Digital vacuum display
- > Vacuum pump 40 m³/h, lubricated with circulating oil
- > Vacuum distributor plate

* depending on the air pressure

Refer to page 35



USER VIDEO
www.barth.tv



MOBILE

mobile and flexible use for customized applications



QUALITY

solid tubular steel construction made in Germany



ENERGY-SAVING

the standard pressure switch starts the vacuum pump only when needed

Base version CORVUS® models

- > Membrane: Natural rubber, highly resilient (silicone membrane upon request)
- > Vacuum pump: dry-running
- > Power: 25 m³/h
- > Tank capacity: 1x 100 l
- > Pressure controller: mechanical
- > Sturdy chassis
- > Additional vacuum connection with 13 mm hose fitting
- > Clamping dimensions Lx W:
CORVUS® 3014: 3,000 x 1,420 mm
CORVUS® 3514: 3,500 x 1,420 mm
- > Footprint Lx Wx H:
CORVUS® 3014: 3,200 x 1,650 x 910 mm
CORVUS® 3514: 3,700 x 1,650 x 910 mm

Optional:

- > Speed-up option (see column on the left)

Recommended accessories:

- > Cover plate for CORVUS®
- > Additional 100l tank

Additional accessories refer to page 48



“After thinking about it for a long time, I exchanged my hydraulic veneer press for a vacuum press from BARTH. Today I am happy that I took this step.”

Thomas Berer,
Schreinerei Berer from
Bad Birnbach

For the complete customer statement, visit us on the Internet at:



CORVUS® 3014.40 speed-up
with optional cover plate

Powerful vacuum pump
with tank **01**

Solid base frame
powder-coated **02**

Speed-up Option
with REVO II pressure switch **03**

Sturdy chassis
4 steering wheels with brake **04**

Natural rubber membrane
highly resilient **05**

Cover plate, folding
protects the membrane against
sunlight (optional) **06**



Instant information:
☎ +49 8634 9827 0
✉ info@barth-maschinenbau.de

CORVUS®-W



The space-saving wall-mounted version CORVUS®-W

For the smallest space requirement we have developed the CORVUS®-W models for wall mounting.

For this series, the vacuum pump and the storage tank are supplied as a standalone unit. The machine can thus easily be folded up when not in use and requires no place in the workshop routine. All the usual advantages of a vacuum press are maintained.

Wall bracket 01

Worktop stiffening 02

Membrane made of highly resilient natural rubber, stretchable up to 600 % 03

Feet easily folding with spring bolts 04



CORVUS®-W folded with optional cover plate

-  **FOLDING**
the vacuum press can be folded when it is not in use
-  **SPACE-SAVING**
when not in use, depth is only 520 mm
-  **SAFE**
support feet can be locked and folded using spring bolts
-  **EFFICIENT**
electronic pressure monitoring with REVO II pressure switch + vacuum distributor plate (speed-up option)

Base version CORVUS®-W models

- > Membrane: Natural rubber, highly resilient (silicone membrane upon request)
- > Vacuum pump: dry-running
- > Power: 25 m³/h
- > Tank capacity: 1x 100l
- > Pressure controller: mechanical
- > Sturdy chassis
- > Additional vacuum connection with 13 mm hose fitting
- > Clamping dimensions Lx W:
CORVUS®-W 3014: 3,000 x 1,420 mm
CORVUS®-W 3514: 3,500 x 1,420 mm
- > Footprint Lx W x H:
CORVUS®-W 3014: 3,500 x 520 x 2,170 mm
CORVUS®-W 3514: 4,000 x 520 x 2,170 mm

Speed-up option

- > Vacuum press, lubricated with circulating oil
- > Power: 40 m³/h
- > Vacuum distribution plate
- > Pressure controller: digital type REVO II, see page 35

The CORVUS®-S models impress with their small footprint. Thanks to the sturdy folding construction in conjunction with the wheels, you can use your vacuum press very flexibly throughout the workshop.

The optional cover plate is not only a protection for the membrane, it also provides a support surface and worktop. The extremely stretchable natural rubber membrane does not leave any desire, even when performing shape bonding.

Pivotable and flexible CORVUS®-S



Base version CORVUS®-S models

- > Membrane: Natural rubber, highly resilient (silicone membrane upon request)
- > Vacuum pump: dry-running
- > Power: 25 m³/h
- > Tank capacity: 1x 100l
- > Pressure controller: mechanical
- > Additional vacuum connection with 13 mm hose fitting for use of the vacuum bag
- > Clamping dimensions L x W:
CORVUS®-S 3014: 3,000 x 1,420 mm
CORVUS®-S 3514: 3,500 x 1,420 mm
- > Footprint L x W x H:
CORVUS®-S 3014 or 3514:
3,290 or 3,790 x 1,650 x 940 mm

Speed-up option

- > Vacuum press, lubricated with circulating oil
- > Power: 40 m³/h
- > Vacuum distribution plate
- > Pressure controller: digital type REVO II, see page 35

100l tank
integrated 01

Mobile
4 steering rollers 02



Instant information:
☎ +49 8634 9827 0
✉ info@barth-maschinenbau.de

The comfort class LUPUS

The compact and cost-effective solution for small bonding from professional do-it-yourselfer to specialized joiner.

The LUPUS series is ideally suited for small and individual part bonding, square timber bonding for turning work up to double-sided surface coating of individual parts in the carcass production. Of course, the shape bonding in the context of the support table is possible. The high quality membrane clamping with the sealing profile is realised in the typical BARTH quality.

Base version LUPUS 1208 and 2312

- > With natural rubber membrane (silicone membranes are optionally available)
- > 3 m suction hose
- > Without vacuum supply
- > Small and lightweight, removable feet
- > Clamping dimensions L x W:
LUPUS 1208: 1.200 x 800 mm
LUPUS 2312: 2.300 x 1.200 mm
- > Footprint L x W x H:
LUPUS 1208: 1.350 x 1.000 x 980 mm
LUPUS 2312: 2.450 x 1.400 x 980 mm



Removable feet 01 Ventilation by ball valve 03
 High quality membrane clamping 02 Vacuum supply vakuuBOX 8.5 optional 04

LUPUS 2312 with optional vakuuBOX 8.5

LUPUS 1208 with optional vakuuBOX 8.5

Dieter Schwab

Many opportunities remain unused!



After many years on the market and in many minds, the vacuum press continues to be a machine for the manufacture of moulded parts. This is undoubtedly the supreme discipline of this machine. However, reducing it to this application gives away the huge range of other possible applications of this machine.

Vacuuming the air below the membrane creates a pressure difference to the outside ambient air pressure. The ambient air presses from the outside on the membrane. The result: Always the same pressing force regardless of the size, shape or thickness of the workpiece. Therefore, the vacuum press is perfectly suited for the flat pressing of uneven materials such as waste wood or split wood boards.

Especially for sensitive coating materials like HPL, the vacuum press offers unbeatable advantages. Anyone who has to process high-gloss laminate in a conventional veneer press knows that every chip, every grain of dust, adhesive tape or glue residue on the press plates inevitably leads to imprints in

the finished surface. This problem is due to the system-related nature of the panel presses as they press all elevations until they are flush with the rest of the pressing surface. This is where the vacuum press has its unbeatable advantages. Glue residues, adhesive tapes for fixing, chips or pieces of cloth that are placed to protect the membranes from the sharp HPL edges do not cause any marks. The feature that vacuum lowers the boiling point of water adds to the above benefits. When using the speed-up option, this effect is so strong that pressing times comparable to heated veneer presses can be achieved without the use of intensive heating. A veneer press consumes on average 12 - 15 kW while a vacuum press does the same job with 0.1 - 0.15 kW.

Practical tip:

In order to obtain safely closed joints in panelling, a pre-tension can be generated with glue presses. For surface bonding, the glue presses are then simply clamped under the membrane. The advantages are obvious, and more and more users benefit from these advantages of a machine that has become indispensable in the factory after a short time. Because creativity is standard in wood-working companies.

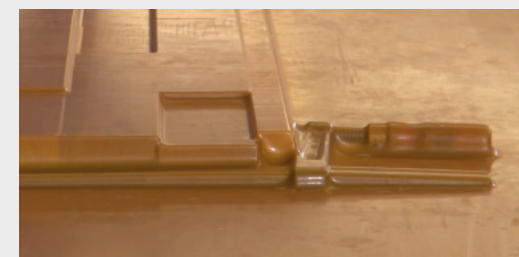

Application examples

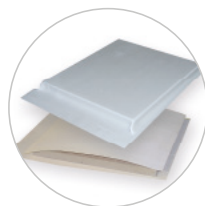

› Coating / Veneering



› Lamination

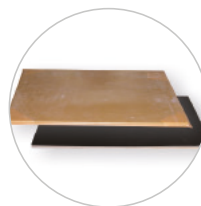

› Surface bonding

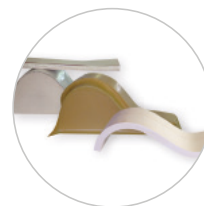

› Form bonding



› Sheathing

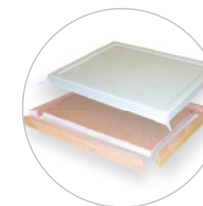

› Edging

Mobile and powerful Vacuum pumps

PT 25.100 / PT 40.100 speed-up

The mobile vacuum generators PT 25.100 and PT 40.100 speed-up supply your vacuum units independently of fixed connections. Internally, they have a powerful vacuum pump feeding a 100 liter supply tank. For devices with low vacuum consumption, two 26 mm hose fittings are provided, as well as a 38 mm hose fitting for the BARTH vacuum presses.



Fig.: PT 25,100

Product information PT 25.100

- > Automatic cutout
- > Power: 25 m³/h, dry-running
- > Tank capacity 100 l
- > Max. vacuum 850 mbar
- > Footprint: 1360 x 560 x 670 mm

PT 40.100 speed-up in addition:

- > Higher press of up to 10 t/m²*
- > Up to 50% shorter pressing times when veneering
- > Electronic pressure monitoring with REVO II pressure switch
- > Digital vacuum display
- > Vacuum pump 40 m³/h, lubricated with circulating oil

* depending on the air pressure



Fig.: PT 40.100 speed-up

vakuuBOX 8.5



Base version vakuuBOX 8.5

- > Dry-running
- > Tank capacity 4.8 litres
- > Max. vacuum 850 mbar
- > Suction power 8 m³/h
- > Manual differential pressure circuit
- > Pressure continuously adjustable up to 85 % vacuum
- > Size LxWxH: 400 x 300 x 330 mm
- > Weight: 21 kg
- > Connection 13 mm nozzle with ball valve
- > Connection with quick coupling for vacuum suction cups

There are no limits

Vacuum bag

Open to all forms and tasks - The vacuum bag

Vacuum bags are the precursors of the modern vacuum presses which are characterized by a simple and cost-efficient technology. They mainly consist of a membrane bag, which is closed on one narrow side. However, they are more complex to handle than modern vacuum presses.

They can be used for press tasks like:

- Veneer bonding
- Form bonding
- Wrapping veneer and
- Edge bonding

For pressing, the workpieces are placed in the vacuum bag which is then hermetically sealed and connected to a vacuum pump. The great advantage of the Barth vacuum bags is the material, an extremely stretchable and resilient natural rubber which is also used in the vacuum presses. So, the vacuum bag does not wrinkle during bending. Barth provides all vacuum bags with a comfortable closure which is always located on the narrow side so that the vacuum bags can be easily and safely closed. The vacuum bags can be bended any way and can be formed to any shape.

The vacuum bags demonstrate their strength when pressing large moulded parts as they only have to take up the material to be pressed. The forming element (template) may be left outside the bag. Alternatively, it is also possible to place suitably stable templates into vacuum bag, as in the vacuum press.



Base version vacuum bag

- › Vacuum bag with one open short side
- › Available widths:
750 mm (usable width 650 ± 20 mm)
1,500 mm (usable width 1,400 ± 20 mm)
- › Available lengths: from 1 m to max. 20 m (in integral meters)
- › Suction nozzle for 13 mm vacuum hose
- › Closure strip
- › Manual slide valve and 5 m vacuum hose



USER VIDEO
www.barth.tv



Machine accessories

REVO II pressure switch

Electronic pressure monitoring with REVO II pressure switch:
 > larger display
 > continuous mode function with timer
 > easy operation with more buttons
 > ergonomic due to larger buttons

Cover plate

Protects the membrane from mechanical damage and UV radiation; provides an easily loadable worktop; easily folding thanks to gas spring support

Vacuum distribution plate, slotted MDF plate

For models	Art.no.
1208	BP-11-1208-28
2312	BP-11-2312-28
3014	BP-25-3014-00-28
3514	BP-25-3514-00-28

Additional 100 l vacuum tank

Ensures an even faster evacuation

Lupus wall bracket

Art. No. BP-11-31
 Wall bracket for LUPUS 2312 and 1208

Membrane accessories

Silicone membrane

Temperature resistant up to 220° C
 Any device can be optionally equipped with a silicone membrane.

Removable frame

For a frequent change of the membrane from natural rubber to silicone, it is recommended to purchase a removable frame as an accessory.

Talcum

Art. no. BP-40-08
 To improve sliding of the membrane on the worktop or the workpiece, it is recommended to dust the membrane with talcum.
 500 g can



Instant information:
 ☎ +49 8634 9827 0
 info@barth-maschinenbau.de

We focus on your requirements

Custom solutions of vacuum presses



Special sizes on request



Heating cover control panel



Upon request with pneumatic/
hydraulic membrane opening

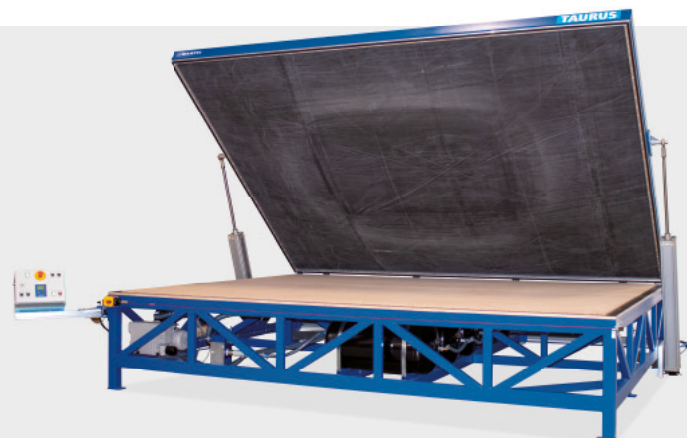

Automated control of the pressing time
and membrane opening. With light barrier
as safety device.

Creative, innovative, efficient

The MULTI-press system

RP / RPW

Page 60/61

› The space-saving allrounder



RPG

Page 56/57

› The smart modular system



Double-sided RPG

upon request

› The smart modular system

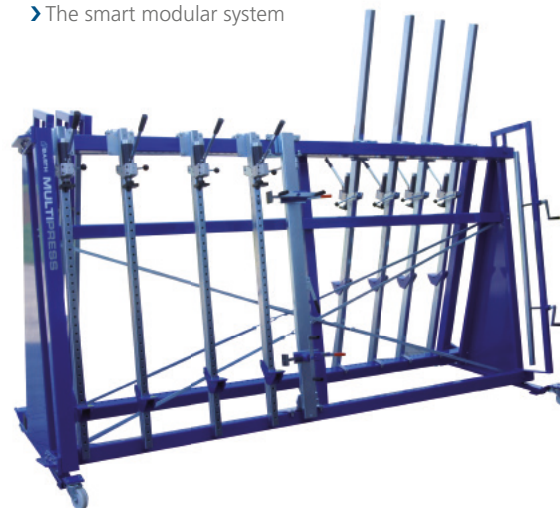

The patented idea of BARTH provides a smart solution regarding the pure frame press. The RPGL provides a hole plate behind a system press.

This RPGL press and assembly center can be used for any bonding and assembly work. Important advantages of such press centers are the smaller footprint as well as the enormous flexibility and versatility.

In particular, the short set-up times must be considered; attachment parts and accessories can be assembled and disassembled without tools.

Type	For bonding clamping dimension (L x H)	For frames * clamping dimension (L x H)	For frames ** clamping dimension (L x H)	For carcasses * clamping dimension (L x H)	For carcasses ** clamping dimension (L x H)	Footprint (L x H x D)	Footprint with central hydraulic system (L x W x T)
RP 2501	2,400x1,580 mm	2,110x1,580 mm	2,050x1,580 mm	2,110x1,340 mm	2,050x1,340 mm	2,560 x 2,250 x 720 mm	2,650 x 2,400 x 730 mm
RP 3001	2,900x1,580 mm	2,610x1,580 mm	2,550x1,580 mm	2,610x1,340 mm	2,550x1,340 mm	3,060 x 2,250 x 720 mm	3,150 x 2,400 x 730 mm
RP 4001	3,900x1,580 mm	3,610x1,580 mm	3,550x1,580 mm	3,610x1,340 mm	3,550x1,340 mm	4,060 x 2,250 x 720 mm	4,150 x 2,400 x 730 mm
RPG 2025 / 2525	2,400x1,580 / 2,080 mm	2,110x1,580 / 2,080 mm	2,050x1,580 / 2,080 mm	2,110x1,340 / 1,840 mm	2,050x1,340 mm	2,580x2,250 / 2,750x800 mm	2,860x2,400 / 2,900x800 mm
RPG 2030 / 2530	2,900x1,580 / 2,080 mm	2,610x1,580 / 2,080 mm	2,550x1,580 / 2,080 mm	2,610x1,340 / 1,840 mm	2,550x1,340 / 1840 mm	3,080x2,250 / 2,750x800 mm	3,360x2,400 / 2,900x800 mm
RPG 2040 / 2540	3,900x1,580 / 2,080 mm	3,610x1,580 / 2,080 mm	3,550x1,580 / 2,080 mm	3,610x1,340 / 1,840 mm	3,550x1,340 / 1,840 mm	4,080x2,250 / 2,750x800 mm	4,360x2,400 / 2,900x800 mm
RPG 2050 / 2550	4,900x1,580 / 2,080 mm	4,610x1,580 / 2,080 mm	4,550x1,580 / 2,080 mm	4,610x1,580 / 2,080 mm	4,550x1,580 / 2,080 mm	5,080x2,250 / 2,750x800 mm	5,360x2,400 / 2,900x800 mm
RPG 2025 double sided	2,400x1,580 mm	2,110x1,580 mm	2,050x1,580 mm	2,110x1,340 mm	2,050x1,340 mm	2,580x1,360x2250 mm	3140x1,510x2250 mm
RPG 2030 double sided	2,900x1,580 mm	2,610x1,580 mm	2,550x1,580 mm	2,610x1,340 mm	2,550x1,340 mm	3,080x1,360x2,250 mm	3,640x1,510x2,250 mm
RPG 2040 double sided	3,900x1,580 mm	3,610x1,580 mm	3,550x1,580 mm	3,610x1,340 mm	3,550x1,340 mm	4,080x1,360x2,250 mm	4,640x1,510x2,250 mm

*Lateral pressure device with rack-and-pinion gears **Lateral pressure device with hydraulic cylinder I with lateral pressure device L +190mm, with movable frame T + 450 mm, H + 25 mm with hold-down clamps H + 90 mm

RPG-NH / RPGL-NH Page 58/59

› Comfort bonding in a modular system



RPGL Page 54/55

› The frame and hole plate press combination

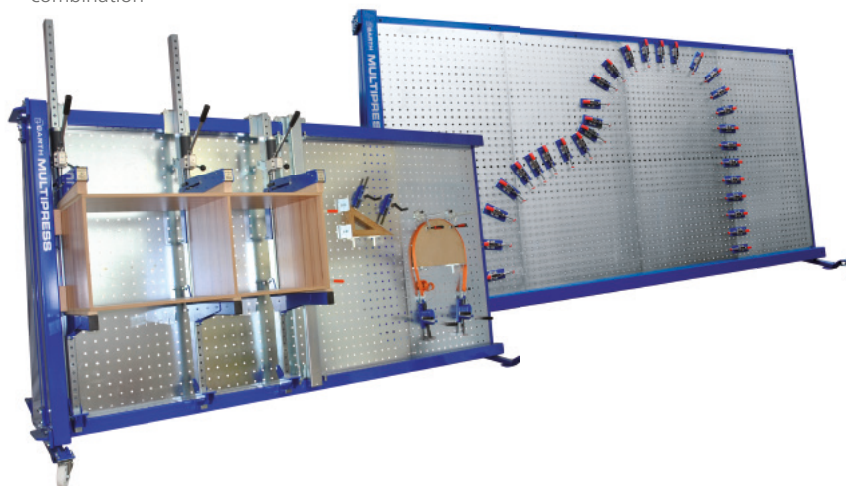

RPL Page 62

› The creative press

RPG-V / RPGL-V Page 52/53

› The space-saving press/bonding center



Type	For bonding clamping dimension (L x H)	For frames * clamping dimension (L x H)	For frames ** clamping dimension (L x H)	For carcasses * clamping dimension (L x H)	For carcasses ** clamping dimension (L x H)	Footprint (L x H x D)	Footprint with central hydraulic system (LxWxT)
RPG-NH 2030	2,900x1,580mm	2,610x1,580mm	2,550x1,580mm	2,610x1,340mm	2,550x1,340mm	3,580x980x2,410mm	3,860x1,130x2,410mm
RPG-NH 2040	3,900x1,580mm	3,610x1,580mm	3,550x1,580mm	3,610x1,340mm	3,550x1,240mm	4,580 x 980 x 2,410mm	4,860x1,130x2,410mm
RPGL 2030 / 2530	2,900x1,580 / 2,080mm	2,610x1,580 / 2,080mm	2,550x1580 / 2,080mm	2,610x1,340 / 1,840mm	2,550x1,340 / 1,840mm	3,080x2,250 / 2,750x800mm	3,360x2,400 / 2,900x800mm
RPGL 2040 / 2540	3,900x1,580 / 2,080mm	3,610x1,580 / 2,080mm	3,550x1,580 / 2,080mm	3,610x1,340 / 1,840mm	3,550x1,340 / 1,840mm	4,080x2,250 / 2,750x800mm	4,360x2,400 / 2,900x800mm
RPL 2030	2,850x1,860	–	–	–	–	3,030x750x2,080mm	–
RPL 2040	3,850x1,860mm	–	–	–	–	4,030x750x2,080mm	–
RPL 2525	2,330x2,390mm	–	–	–	–	2,530 x 900 x 2,570mm	–
RPL 2530	2,830x2,390mm	–	–	–	–	3,030 x 900 x 2,570mm	–
RPL 2540	3,830x2,390mm	–	–	–	–	4,030 x 900 x 2,570mm	–
RPL 3240	3,850x3,060mm	–	–	–	–	4,030x1,200x3,200mm	–
RPL 3250	4,850x3,060mm	–	–	–	–	5,030 x 1,200 x 3,200mm	–
RPG-V 2033 / 2533	3,250x1,580 / 2,080mm	2,960x1,580 / 2,080mm	2,900x1,580 / 2,080mm	2,960x1,340 / 1,840mm	2,900x1,340 / 1,840mm	3,420x2,250 / 2,750x1,260mm	3.660x2.400 / 2.900x1,200mm
RPG-V 2038 / 2538	3,750x1,580 / 2,080mm	3,460x1,580 / 2,080mm	3,400x1,580 / 2,080mm	3,460x1,340 / 1,840mm	3,400 x1,340 / 1,840mm	3,920 x 2,250 / 2,750 x 1,260mm	4,160 x 2,400 / 2,900 x 1,200mm

*Lateral pressure device with rack-and-pinion gears **Lateral pressure device with hydraulic cylinder I with lateral pressure device L +190mm, with movable frame T + 450mm, H + 25 mm with hold-down clamps H + 90mm

The space-saving press center for any bonding work

Bonding center

The best of both worlds for any bonding work - a combination of space saving and efficient! The fusion of a MULTI-press and a vacuum membrane press.

On the one hand, a MULTI press RPG, which can be individually equipped to fit your needs. In addition, you can add accessories at any time to expand it to a carcass press (see following pages). The RPGL-V hole plate opens up all possibilities for bonding work and the largest possible field of application.

On the other hand, you have all the benefits of the vacuum press CORVUS®-W (see page 42). Expand your workplace while saving space. When not in use, simply fold up the vacuum press and the support feet secured by a spring bolt.

Your biggest benefit:
You can process several workpieces simultaneously in less time!



Vacuum press with cover plate, to be used as work table



Low space requirement and mobile

Base version RPG-V models

- > Solid base frame
- > 90° stop
- > Folding vacuum press
- > Vacuum press (dry-running)
- > 100 l tank

Basic equipment RPGL-V models

- In addition,
- > 6 mm steel hole plate with 70 mm hole grid

Dimensions, refer to table on page 51

Speed-up option:

- Advantages
- > Higher pressure
 - > Up to 50% shorter press times
 - > Electronically maximised pressure

Additional scope of supply

- > Vacuum press, lubricated with circulating oil
- > Power: 40 m³/h
- > Pressure controller: digital type REVO II, Benefits, refer to page 35
- > Vacuum distributor plate

- SPACE-SAVING**
through folding vacuum press
- UNIVERSAL USE**
frame, surface, stands, carcass, ...
- SYSTEM PRESS**
expandable at any time with accessories up to a carcass press (not possible with rack-and-pinion gear)
- QUICK SET-UP**
tool-free attachment and removal of accessories
- EFFICIENT**
increasing the value-adding time for manual work
- QUALITY**
solid steel frame, resistant surfaces, made in Germany
- MOBILE**
upon request with moving device



Instant information:
 +49 8634 9827 0
info@barth-maschinenbau.de

MULTI-press RPG-V / RPGL-V



RPGL-V with hole plate with optional accessories

RPG-V with optional accessories
Various additional accessories, refer to page 65



USER VIDEO
www.barth.tv



BARTH

Cover plate 01
optional, perfect as a large-surface worktable

Natural rubber membrane 02
highly resilient

Vacuum tank 03
integrated

Sturdy chassis 04
for increased flexibility (optional)

Press unit 20 05
smooth-running, guided by ball bearings

Manual hydraulic cylinder HSH01 06
100 mm stroke, 2-step pump system
2,000 kg pressing force

Solid base frame 07
powder-coated surface

Hold-down clamps 08
with trapezoidal spindle (optional)

Hole plate 09

The frame and hole plate combination

MULTI-Press RPGL 20 / RPGL 25

The models of the BARTH Multipress RPGL have not only been designed for bonding.

They are also used as ergonomic assembly device which should be considered when designing the workplace. The BARTH press and assembly center RPGL is based on the base frame of the MULTI-Press RPG and offers many possibilities to perform bonding and assembly tasks quickly and without long changeover times.

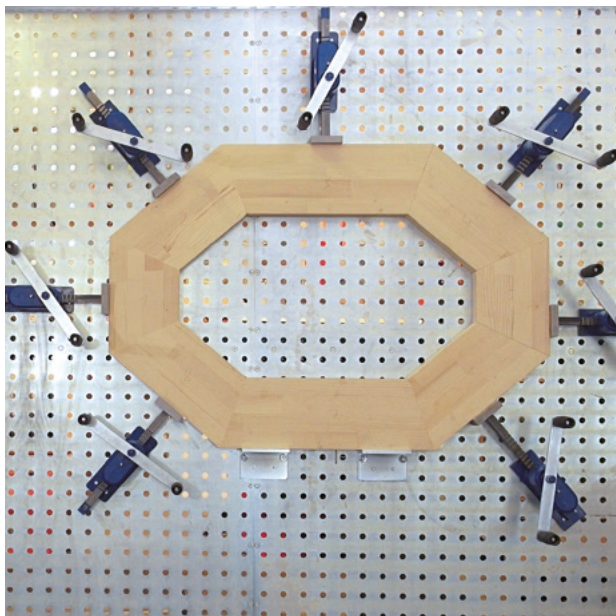

Template and polygon bonding

Round bonding with blet elements

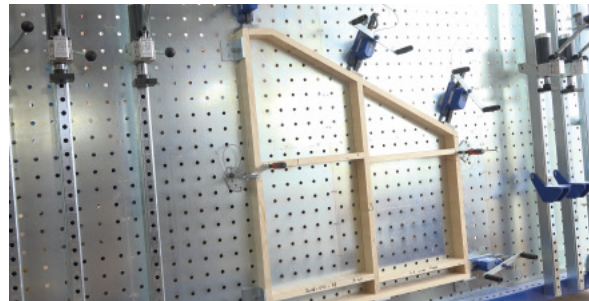
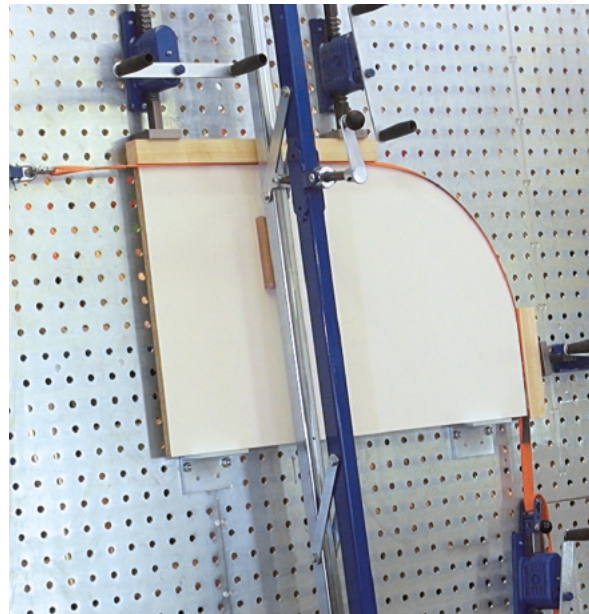

- 
UNIVERSAL USE
 frame, surface, stands, carcass, ...
- 
QUICK SET-UP
 tool-free attachment and removal of accessories
- 
EFFICIENT
 increasing the value-adding time for manual work
- 
SYSTEM PRESS
 expandable at any time with accessories up to a carcass press (not possible with rack-and-pinion gear)

Base version of the RPGL 20 models

- > Base frame made of a solid steel frame
- > Powder-coated surface
- > Hole plate integrated in the base frame, 6 mm steel, galvanized surface
- > 90° stop for the hole plate level
- > 90° stop for the press units level

Base version of the RPGL 25 models

- > Like RPGL 20 but: Higher 90° stop for the press units level (+500mm)

Dimensions, refer to table on page 51



USER VIDEO
www.barth.tv



MULTI-Press RPGL 20 / RPGL 25



We are bonding a lot of solid wood and are very happy with the BARTH MULTI-press. The press is, among others, very good to use for our staircase construction. Even bent parts like strings or handrails can be pressed by the high hydraulic pressure. The hydraulics also protect the wrists as, compared to glue presses, you can work with little effort."

Schreinerei Kirchberger,
94034 Passau

For the complete customer statement, visit us on the Internet at:



www.barth.tv

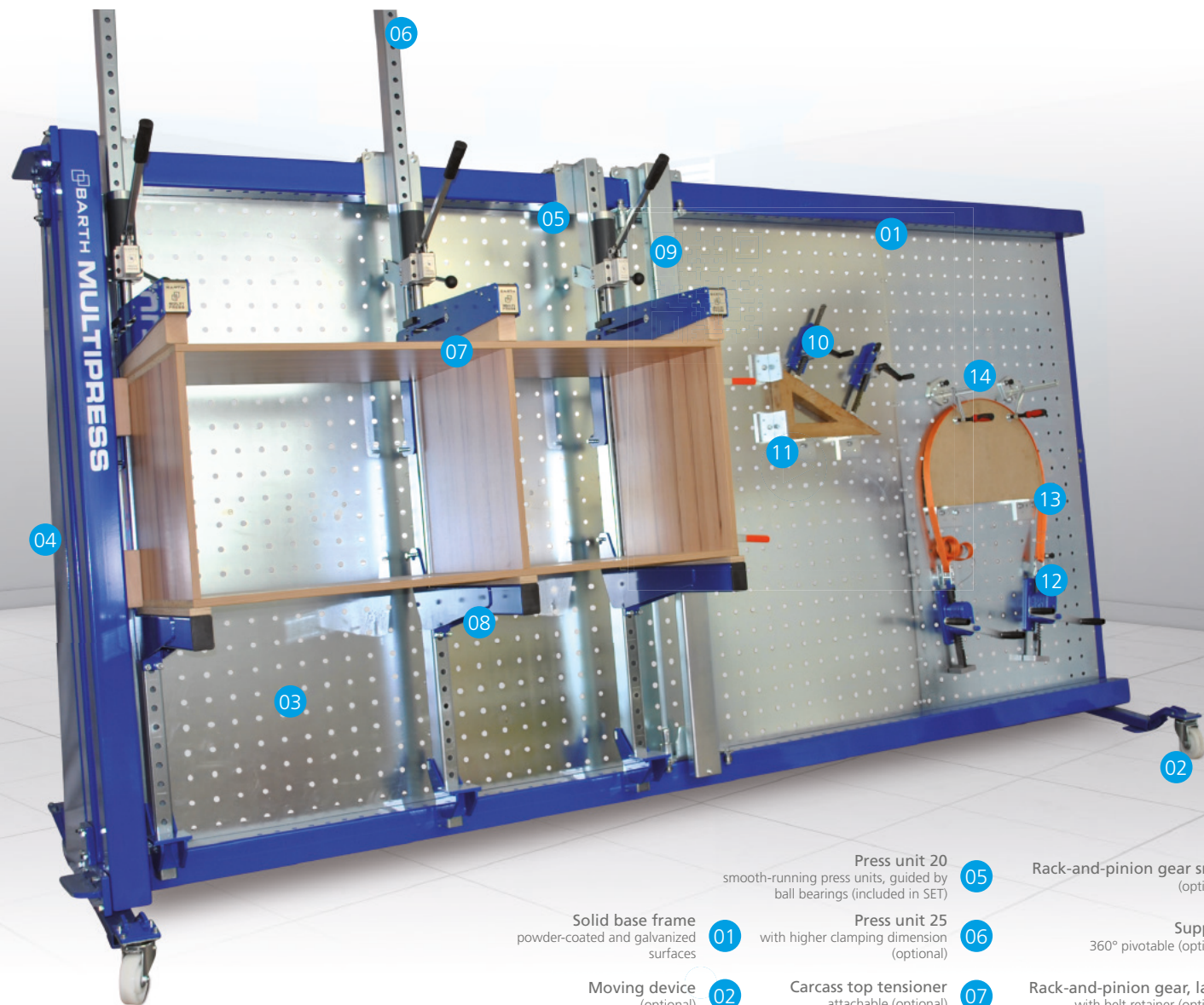

RPGL 2040 with optional accessories
Accessories, refer to pages 65 and 66

- 01 Solid base frame powder-coated and galvanized surfaces
- 02 Moving device (optional)
- 03 Hole plate solid steel plate 6 mm with precision hole grid 70 mm
- 04 Stops 90° stops on two levels
- 05 Press unit 20 smooth-running press units, guided by ball bearings (included in SET)
- 06 Press unit 25 with higher clamping dimension (optional)
- 07 Carcass top tensioner attachable (optional)
- 08 Carcass support attachable (optional)
- 09 Lateral pressure device
- 10 Rack-and-pinion gear small (optional)
- 11 Support 360° pivotable (optional)
- 12 Rack-and-pinion gear, large with belt retainer (optional)
- 13 Belt optional
- 14 Vertical clamping device optional

The smart modular system for your workshop

MULTI-Press RPG 20 / RPG 25

BARTH develops and manufactures universal system presses for efficient processing of:

- > Carcass
- > Frames
- > Stands and plates

They have been especially developed to carry out sizing work in a quick and cost-effective way. Productivity in your workshop increases and you save time. Even intractable wood cannot withstand the system presses. With a clamping force of up to 2,000 kg, they bring each piece into the correct position with the turn of your hand. Customers always expect 100% quality with strong and uniform glued joints. BARTH system presses are a future-proof investment.

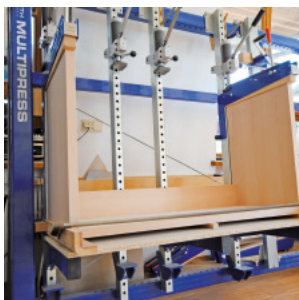

Base version of the RPG 20 models

- > Base frame made of a solid steel frame
- > 90° stop on the left side
- > Solid cross-bracing
- > Powder-coated surface

Base version of the RPG 25 models

- > Like RPG 20, but higher 90° stop (+ 500 mm)

On request, the frame is also delivered disassembled. Dimensions, refer to table on page 50

-  **SYSTEM PRESS**
expandable at any time with accessories up to a carcass press (not possible with rack-and-pinion gear)
-  **QUICK SET-UP**
tool-free attachment and removal of accessories
-  **UNIVERSAL USE**
frame, surface, stands, carcass, ...
-  **QUALITY**
solid steel frame, resistant surfaces, made in Germany
-  **EFFICIENT**
increasing the value-adding time for manual work



USER VIDEO
www.barth.tv



02:12

02:12



„The MULTI-press RPG 2040 has given us many advantages for the effectiveness of our production!“

Schreinerei Huber aus Kirchbichl



RPG 2040 with optional accessories
Various additional accessories, refer to page 65



... more
DETAILS!

Instant information:

+49 8634 9827 0

info@barth-maschinenbau.de

- 01 **Sturdy base frame**
made of thick-walled hollow profile -
screwed
- 02 **Sturdy chassis**
for increased flexibility (optional)
- 03 **Carcass bonding**
up to a depth of 600 mm
- 04 **Press unit 20**
with manual hydraulic cylinder HSH01
- 05 **Additional 90° stop**
attachable (optional)
- 06 **Hold-down clamp**
optional
- 07 **Surface bonding**
straight or inclined with optional
rotating shoes
- 08 **Lateral pressure device**

Comfort bonding in a modular system

MULTI-Press RPG-NH

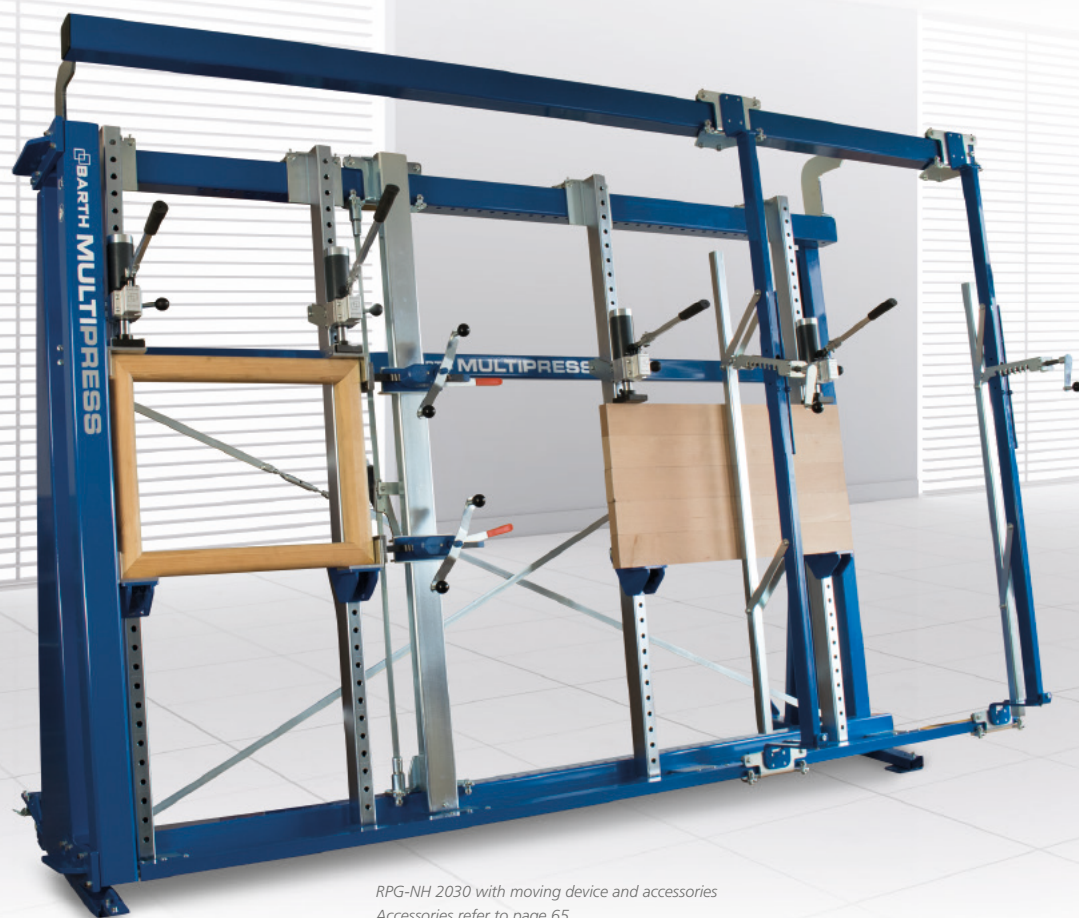

RPG-NH 2030 with moving device and accessories
Accessories refer to page 65

Everyone who has to carry out a lot of wide bonding every day will be glad about the easy operation of the mobile hold-down clamps.

The hold-down clamp is recommended for each wide bonding, e.g. tabletops. It prevents the edges from sliding on the glue joint. Thus, a high surface removal by grinding or even planing is not necessary. The high pressure prevents the edges from protruding. This increases safety considerably. The conventional hold-down clamp is mounted for any bonding and, removed afterwards. The mobile hold-down clamp is simply pushed on ball bearing guides over the surface to the side. The hand levers of the manual hydraulic cylinders simply fold away.

More comfort is not possible!

Base version RPG-NH models

- > Base frame
- > 90° stop
- > Guide rails for mobile hold-down clamp
- > 2 mobile hold-down clamps

Dimensions, refer to table on page 51



Comfort bonding in a modular system

MULTI-Press RPGL-NH

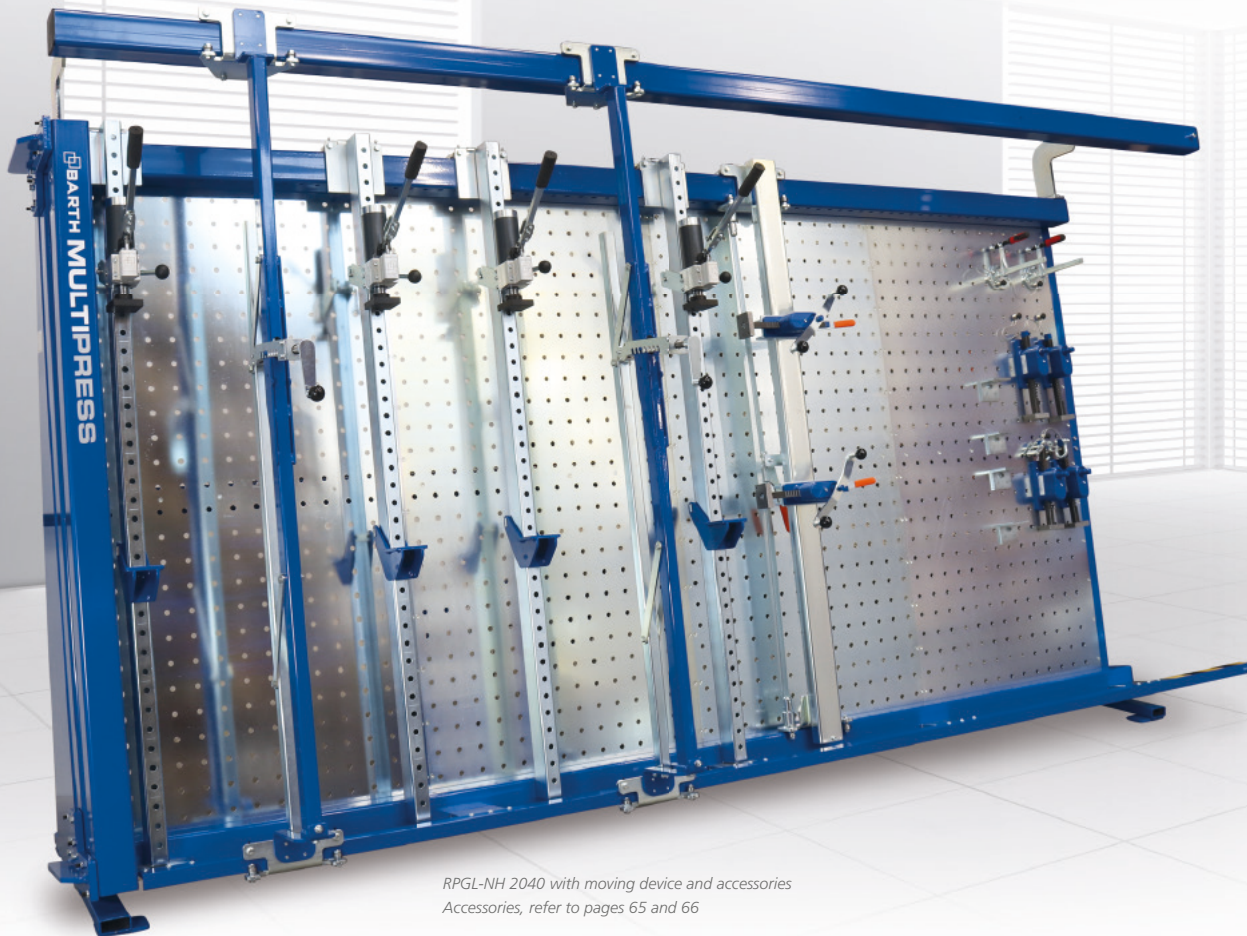

RPGL-NH 2040 with moving device and accessories
Accessories, refer to pages 65 and 66

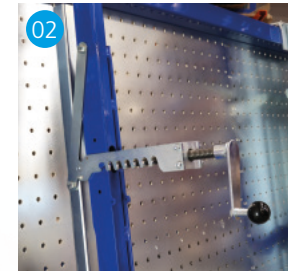
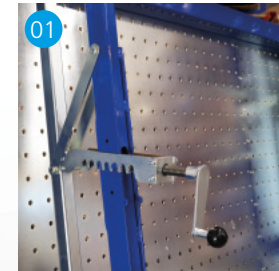

Hold-down clamp quick adjustment (also applies to RPGL-NH) 01 02

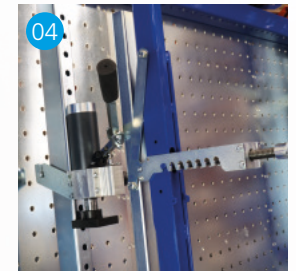

Rack-and-pinion-gear of lateral pressure device with offset manual crank (also applies to RPGL-NH) 03

Folding hand lever swivels away for the hold-down clamp (also applies to RPGL-NH) 04

Base version RPGL-NH models

- > 6 mm steel hole plate, hole grid 70 mm
- > Base frame
- > 90° stop
- > Guide rails for mobile hold-down clamp
- > 2 mobile hold-down clamps

The space-saving allrounder MULTI-Press RP / RPW

Bonding with glue presses on trestles is very time-consuming and requires a large surface in the bench area.

The presses of the RP series are mobile and space-saving when used in the workshops. Difficult and time-consuming bonding with glue presses is no longer necessary, considerably reducing the assembly times. No matter if frame, carcass, plate or stand bonding; the solid construction of the MULTI-press and the pressure cylinders HSH 01 especially designed for woodworking support you with full power.

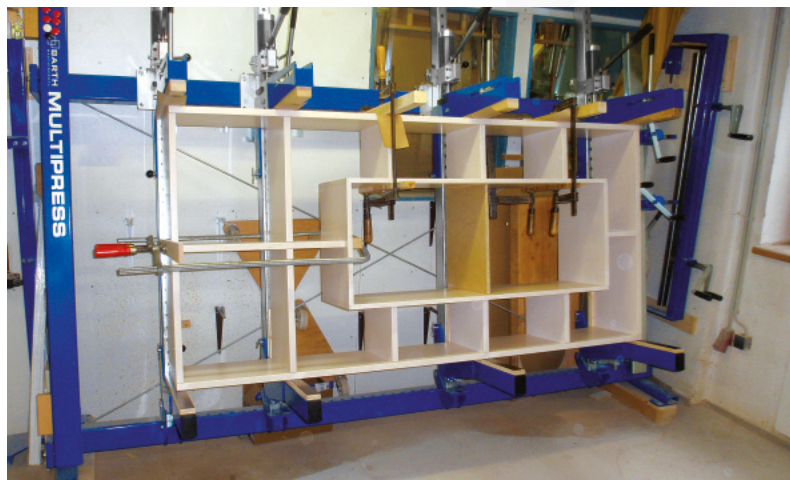

UNIVERSAL USE

frame, surface, stands, carcass, ...



SYSTEM PRESS

expandable at any time with accessories up to a carcass press (not possible with rack-and-pinion gear)



QUICK SET-UP

tool-free attachment and removal of accessories



EFFICIENT

increasing the value-adding time for manual work



QUALITY

solid steel frame, resistant surfaces, made in Germany

Base version RP models

- > 3 press units with manual hydraulics HSH01 pressure elements 100 mm stroke, 2,000 pressing force
- > 90° stop
- > The MULTI-Press RP is expandable at any time with the components of the MULTI-Press system
- > Also available with central hydraulic system

Base version RPW models

- > 3 press units with rack-and-pinion gear with 140 mm stroke, 1,000 pressing force
- > 90° stop
- > The MULTI-Press RPW is expandable at any time with the components of the MULTI-Press system..

On request, the frame is also delivered disassembled.

Dimensions, refer to table on page 50



Base version of RPW

RP with optional accessories



USER VIDEO
www.barth.tv



- 01 Solid base frame powder-coated surfaces
- 02 Sturdy feet chassis (optional, refer to page 66)
- 03 90° stop
- 04 Solid square pipes with 50 mm precision pitch pattern, galvanized surface
- 05 Mech. rack-and-pinion gear 140 mm stroke, 1,000 kg pressing force
- 06 Press units continuously mobile, guided by ball bearings
- 07 Manual hydraulic cylinder HSH01 100 mm stroke, 2-step pump system 2,000 kg pressing force
- 08 Hold-down clamp RP with 2 trapezoidal spindles (optional)

-  **EFFICIENT**
no providing of particularly made bonding equipment
-  **SETTING**
individual arrangement of bonding tools in 70 mm hole grid
-  **FLEXIBLE**
extension with retrofittable accessories
-  **COMFORTABLE**
operation with low effort due to leverage effect
-  **MOBILE**
mobile use thanks to smooth-running chassis (optional)
-  **SET-UP TIMES**
uniform tool holder in 70 mm hole grid

With the BARTH hole plate press RPL your ideas have no limits.

Due to the small hole pitch of 70 mm and the large stroke of the rack-and-pinion gear, any contour can be pressed. The laser-cut precision holes are precisely positioned to 0.1 mm. The hole plate press is available in various standard sizes (refer to table on page 51). Special solutions are possible on request.

The creative press MULTI-Press RPL

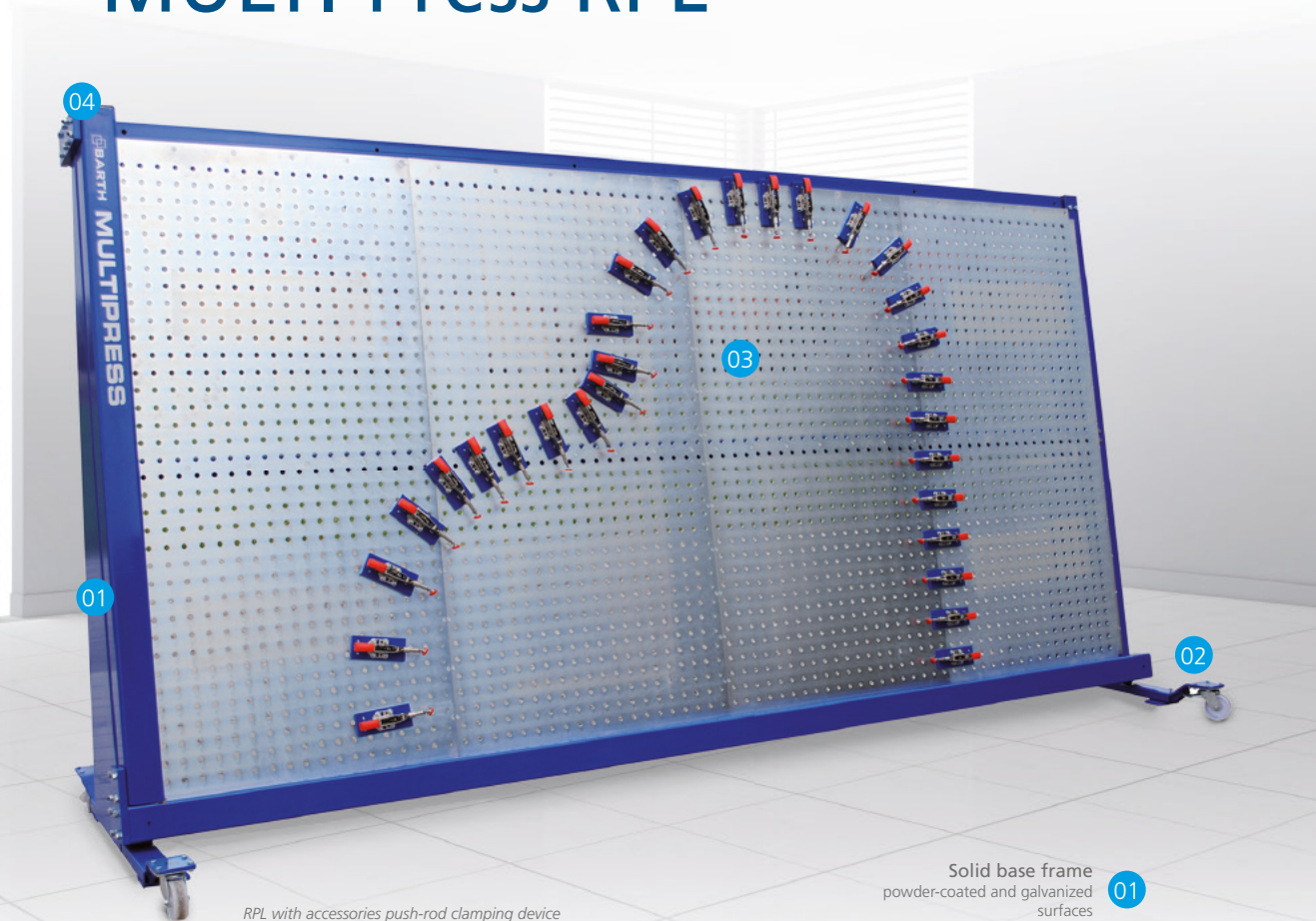

RPL with accessories push-rod clamping device
Various additional accessories, refer to page 66

Base version RPL

- > 6 mm steel hole plate, hole grid 70 mm
- > 90° stop

Various accessories, refer to page 66
Dimensions, refer to table on page 51



Instant information:
☎ +49 8634 9827 0
✉ info@barth-maschinenbau.de

- 01 Solid base frame powder-coated and galvanized surfaces
- 02 Sturdy moving device up to size 2540 (optional)
- 03 Push-rod clamping device (optional)
- 04 90° stop

BARTH press technology

Manual hydraulic cylinder HSH01



Time saving

The time saving and the high pressure allow the use of a glue with short curing times. In this way, a double time saving is achieved!

100 mm stroke

The extended stroke also allows the pressing of dowel connections in large lengths in only one pass. This saves time!

2,000 kg pressing force

Due to the high pressure an even thinner, exact glued joint is achieved! The result is a barely visible glued joint!

2-step pump system

The distance up to the workpiece is covered by a quick stroke. This saves time! For pressure build-up, the system automatically switches to pressure stroke. Thus, the maximum pressure of 2,000 kg is easily reached.

One-hand operation

Clamping and unclamping with one handle! No additional valve for unclamping - simply push the handle upwards. Thus, one hand is free to clamp, hold or position the workpiece.

Overload protection

After reaching the maximum pressure, an overpressure valve protects the entire system, to ensure its longevity!

The ergonomic and technical special hydraulic system, the manual hydraulic clamping system, has been developed by BARTH. When developing this hydraulic clamping system, absolute closeness to practice was right at the top of the specifications. The one-handed operation allows clamping and unclamping with a handle. The operating element was positioned as far down as possible. Thus, accessibility and ergonomics of the operating lever are significantly improved for larger workpieces.

The manual clamping hydraulics are equipped with an innovative quick stroke and automatic switchover to the pressure stroke. The large lifting range of 100 mm avoids "repositioning" of the hydraulics with long dowel connections. The large stroke significantly facilitates the equipment of the carcass function.



Retrofittable also for many third party

e.g. retrofitting kit for HESS press
Art. BM-35-03-02-71

Solutions for trade and industry

BARTH press technology innovations

Rack-and-pinion gear



Suitable for	Art.no.
RPW models	BM-35-02
RPG models	BM-60-02

Affordable pressure element, which works purely mechanically with a self-locking gear transmission.

Advantages

- > 140 mm stroke
- > Pressure approx. 1,000 kg
- > Very quick stroke

Comfort equipment



Suitable for	Art.no.
RPG models	BM-60-41
RPGL models	BM-70-41

The pressure is produced easily and sensitively by hand lever at a central location. All pressure elements are enabled at the same time. Any cylinder can be disabled individually.

Advantages

- > Single hand lever operation for clamping and unclamping
- > 2-step pump system
- > Fast stroke/pressure stroke with automatic switching
- > 100 mm stroke
- > 2,000 kg pressing force

Pro equipment

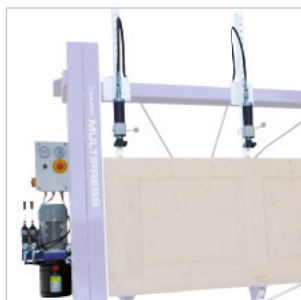

Suitable for	Art.no.
1 circuit unit RPG	BM-60-43
1 circuit unit RPGL	BM-70-43
2 circuit unit RPG	BM-60-44
2 circuit unit RPGL	BM-70-44

Pressure build-up takes place at a central location without any effort using the electrical unit.

Advantages

- > Central pressure supply via electrical hydraulic unit
- > It is possible to work with several pressure circuits, e.g. 1st circuit vertical and 2nd circuit horizontal or 1st circuit on the left and 2nd circuit on the right.
- > 100 mm stroke
- > 2,000 kg pressing force

DUAL



Suitable for	Art.no.
RPG models	BM-60-42
RPGL models	BM-70-42

The benefits of the manual hydraulic cylinders and the Comfort equipment are combined here. As needed, control can be performed individually on the cylinder or conveniently on the central pump unit.

Advantages

- > Control performed centrally or individually per cylinder
- > Single hand lever operation for clamping and unclamping
- > 2-step pump system
- > Fast stroke/pressure stroke with automatic switching
- > 100 mm stroke
- > 2,000 kg pressing force

eDUAL



Suitable for	Art.no.
1 circuit unit RPG	BM-60-45
1 circuit unit RPGL	BM-70-45
2 circuit unit RPG	BM-60-46
2 circuit unit RPGL	BM-70-46

The benefits of the manual hydraulic cylinders and the Pro equipment are combined here. As needed, the cylinder can be actuated manually from the central unit or very comfortably using the electro-hydraulic unit.

Advantages

- > Central pressure supply via electrical hydraulic unit
- > Control performed centrally or manually and individually per cylinder
- > 100 mm stroke
- > 2,000 kg pressing force

Pneumatic equipment



- > Upon request
- > Max. pressure 500 kg per cylinder
- > Various control options
- > Ideal for large-scale production

ACCESSORIES

Thanks to the BARTH modular system, your BARTH MULTI-press adapts to the growing requirements. For example, various attachments can convert a simple bonding press into a frame or even a carcass press. With the BARTH MULTI-press system press, there is no reason why an order-related extension should not be possible - an important decision-making criterion.

Press units

Rack-and-pinion gear



Suitable for	Art.no.
RPG models	BM-60-02
RPW models	BM-35-02

Manual hydraulic cylinder



Suitable for	Art.no.
RP models	BM-35-03
RPG (L) 20 models	BM-60-03
RPG (L) 25 models with higher clamping dimension	BM-60-07
RPG-NH models	BM-65-03

Central hydraulic cylinder



Suitable for	Art.no.
RP-Comfort / RP-Pro	BM-55-04
RPG (L/NH) 20 Comfort/Pro	BM-60-04
RPG (L/NH) 25 Comfort/Pro with higher clamping dimension	BM-60-08

DUAL hydraulic cylinder



Suitable for	Art.no.
RPG (L) 20 DUAL/eDUAL	BM-60-06
RPG (L) 25 DUAL/eDUAL with higher clamping dimension	BM-60-09
RPG-NH models	BM-65-06



Lateral pressure devices

with 2 rack-and-pinion gears

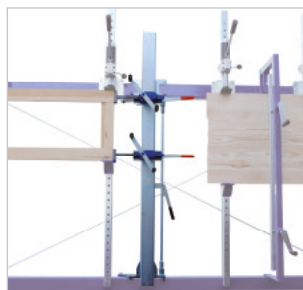

Suitable for	Art.no.
RP (W) models	BM-35-20
RPG/RPGL models	BM-70-20
RPG 25 models	BM-60-23
RPG-NH models	BM-65-20

with 2 manual hydraulic cylinders



Suitable for	Art.no.
RP models	BM-35-22
RPG/RPGL models	BM-70-22
RPG 25 models	BM-60-25
RPG-NH models	BM-65-22

90° stop to attach



Suitable for	Art.no.
RPG (L) 20 models	BM-60-29
RPG (L) 25 models with higher clamping dimension	BM-60-31

Hold-down clamps

Hold-down clamp



Suitable for	Art.no.
RP models	BM-35-10
RPGL (hole plate level)	BM-70-11

Hold-down clamp plus



Suitable for	Art.no.
RPG models	BM-60-11
RPGL (press unit level)	BM-70-12
RPGL (hole plate level)	BM-70-13

Various accessories

Carcass top tensioner



Suitable for	Art.no.
all except RPW	BM-35-42
carcass set: 1X carcass top tensioner and 1x carcass support	BM-35-46

Carcass support



Suitable for	Art.no.
all models	BM-35-41
carcass set: 1X carcass top tensioner and 1x carcass support	BM-35-46

Movable frame

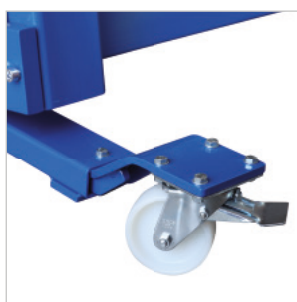

Suitable for	Art.no.
RP / RPW models	BM-35-55
reinforced version	BM-70-55

Mitre bonding device

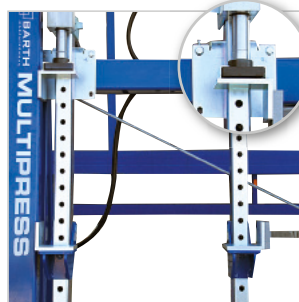

Suitable for	Art.no.
all models Set, includes 4 brackets	BM-35-57

Swivel-mounted shoe ± 30°



Suitable for	Art.no.
all models	BM-35-56

Drawer set resp. with 150 mm support shoe



Pressure point offset for...	Art.no.
30 mm	BM-35-43
50 mm	BM-35-45

Accessories for 6 mm steel hole plate (hole diameter 15.5 mm)

Rack-and-pinion gear, small



	Art.no.
small	BM-70-31

Rack-and-pinion gear, large, for hole plate

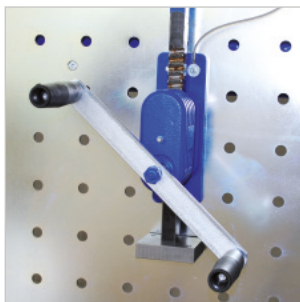

	Art.no.
large	BM-70-33
large for belt retainer	BM-70-05

Belt with turnbuckle



	Art.no.
length 3,000 mm	BM-70-05-0300

Support

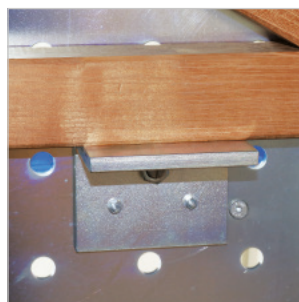

	Art.no.
360° pivotable	BM-70-34

Vertical clamping device



	Art.no.
with 2K handle, jaw capacity, clamping height 200 mm	BM-70-38

Push rod clamping device

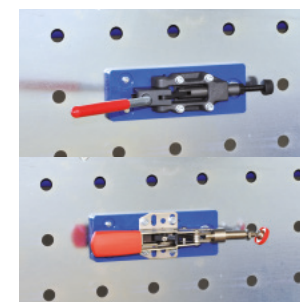

	Art.no.
without spring	BM-70-36
with spring	BM-70-37

BM-70-36
BM-70-37

More than 30 years of experience

Custom solutions for frame and bonding presses

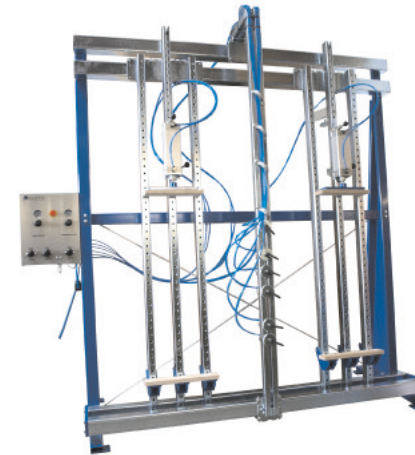
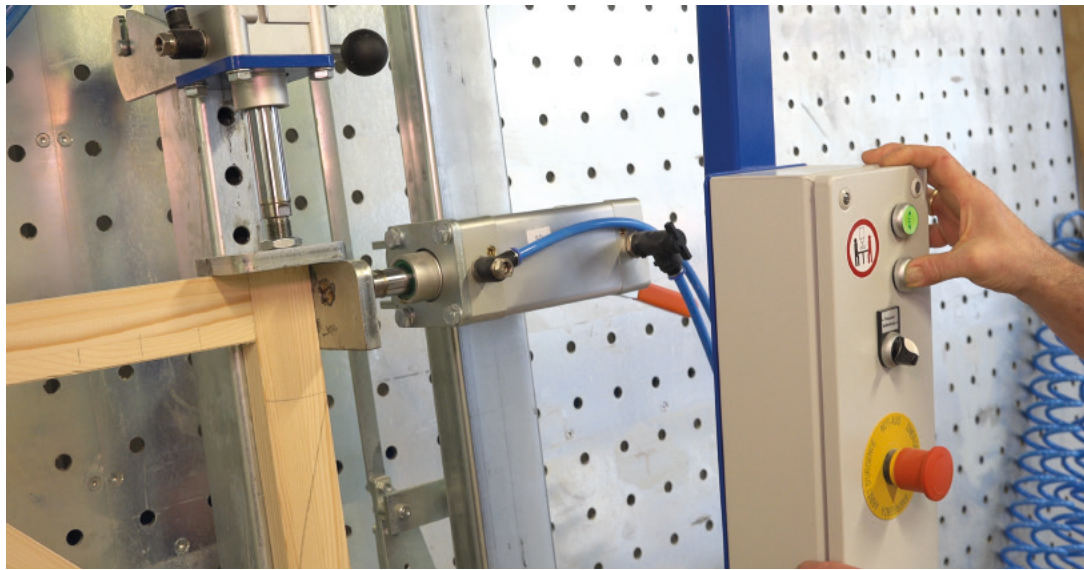

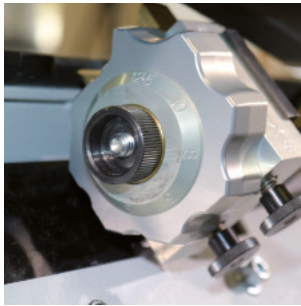

For a perfect edge finishing

Round & chamfer grinding machine

Profiling and grinding are two operations which are carried out in different ways and using different procedures.

This usually requires a significant amount of manual work. With this machine, we offer a system allowing to perform such operations quickly and accurately in a continuous process. Our universal machine type, equipped with an extra-long machine table and easily adjustable pre-milling unit ensures time-saving complete machining of curved or chamfered edges in one operation.



Easy adjustment of the milling depth



Instant information:

+49 8634 9827 0

info@barth-maschinenbau.de

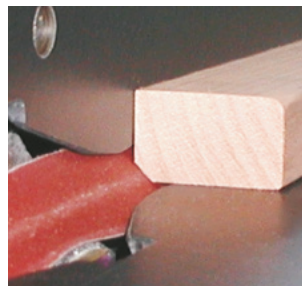

45° chamfer

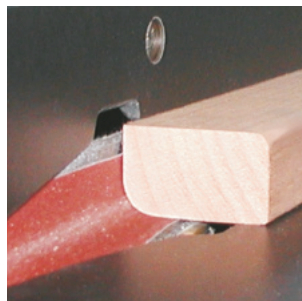

Curve

Base version RFM 320

- > Adjustable grinding tool for 8 radii (2, 3, 4, 5, 6, 8, 10 and 12.5mm)
- > Chamfering equipment up to 16 mm depth (continuously)
- > Grinding belt oscillation with pneumatic belt cleaning
- > Integrated base for feed unit
- > 16A socket for feed unit
- > Suction connection Ø 80 mm

RFM 320S, in addition

- > Pre-milling unit 1,100W / 220 V, continuously adjustable up to 25,000 rpm
- > Milling range up to radius 12 mm

SET variant, in addition

- > Movable frame with 2 lockable 2 steering rollers
- > Workpiece support, 380 mm pulled-out width



PARTICULARLY ECONOMICAL
mechanical belt oscillation, pneumatic belt cleaning and gentle belt guidance via a specially modified graphite sliding coating ensure a long service life of the grinding belts of 2,300mm in length



SHORT SET-UP TIMES
easy adjustment of curve or chamfer, maximum time savings even with single pieces



BEST GRINDING QUALITY
precise calibration of curve or chamfer, clean transition into the surfaces, by means of finely adjustable belt guide jaws



WIDE RANGE OF RADII
the use of individual radius modules makes it possible to perfectly grind even curves over 12.5 mm, up to radius 25 mm, e.g. handrails

Footprint L x W x H in mm

- > RFM 320: 1,300 x 650 x 960 mm
- > RFM 320 SET (incl. chassis and workpiece support): 1,300 x 690 x 1,010 mm
- > RFM 320S: 1,600 x 650 x 1,000 mm
- > RFM 320S SET (incl. chassis and workpiece support): 1,600 x 690 x 1,050 mm



"We build winter gardens and have lots of edges to round and sand. We used to sand it all by hand. We have used the RFM radius and chamfer grinding machine for 2 years and are very impressed as we can exactly process all rounds in one operation."

Eichinger Schreinerei GmbH,
94152 Neuhaus
am Inn



Important accessories

> The standard version of both machine types is equipped with a mounting base and a socket for a feed unit.



> Radii grinding



> Chamfer grinding



> Pre-milling

For the complete customer statement, visit us on the Internet at:



RFM 320 **01**
without pre-milling unit

Grinding area **02**

Workpiece support
extendable by 380 mm
(Included in SET-Variant) **03**

Chassis
(Included in SET-Variant) **04**

RFM 320S **05**
with pre-milling unit

Grinding area **06**

Workpiece support
extendable by 380 mm
(Included in SET-Variant) **07**

Pre-milling unit
easily adjustable **08**

For sliding table saws

Swivelling fence

Finally, a swivelling fence that protects the mitre cut and allows for an exact cut. With a stop length of 1.10 m, your workpiece will be optimally held. Angles from 0° to 45° with perfect support on the swivelling fence ensure the exact cut because the workpiece can no longer slip under the fence. For a guaranteed long-lasting function, the BARTH swivelling fence is made of a solid construction and can nevertheless be mounted quickly and easily.

- PROTECTION**
perfect mitre protection
- FLEXIBLE**
individual use
- SIZE**
large support surface

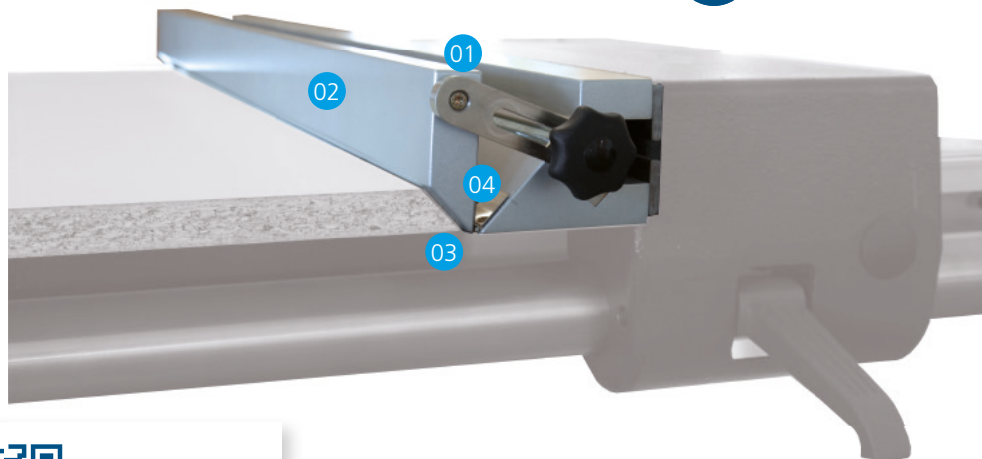

USER VIDEO
www.barth.tv



- Sturdy construction
- Optimum protection for the mitre
- Fence length 1,100mm
- Angles from 0° to 45°

BARTH Referenzen

Trade ...



Möbel und Raum GmbH & CO. KG
www.moebelundraum.net



Schreinerei Peter Kurz
www.schreinerei-peter-kurz.de



Athmer & Söhne
www.athmer-und-soehne.de



Margreiter GmbH
www.margreiter-moebelmanufaktur.com



Linnemann
www.linnemann-einrichtungen.de

Industry ...



Oldenburger Möbelwerkstätten GmbH
www.oldenburger.com



Palmberg Büroeinrichtungen
+ Service GmbH
www.palmberg.de



Energiesparen und Klimaschutz serienmäßig

Wolf GmbH
www.wolf.eu



a family affair since 1877

Barth Brixen
www.barth.it



Design Comoposite GmbH
www.design-composite.com

Our customers



USER VIDEOS
www.barth-maschinenbau.de/videos/



Robert Rager – Staatstheater Augsburg

"We have chosen a frame press from BARTH as it is incredibly flexible to use. In addition, we ordered the hole plate as it also allows to press relatively slanting, bulky frames."

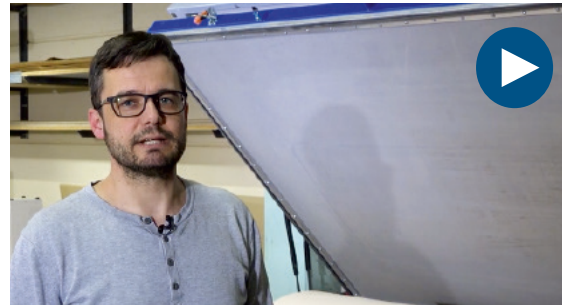

Bastian Weippert – commod - Feines in Holz

"Together with the BARTH company, we have made observations on how we could make our employees' work easier and ergonomically better. We are very satisfied with the products and thank you."



Bernd Lotter – Lotter-Objekt, Kelheim

"The ergonomics of the lifting tables are gladly accepted by the employees. Large, heavy workpieces can be processed at the correct working height."



Thomas Huber – Bau- & Möbeltischlerei, Kirchbichl

"A very important investment for us was the acquisition of, among other things, the vacuum units from BARTH – stand-alone or mounted directly on the workbench. They really pay off! The gain in surface quality is brilliant, the added value is enormous! There are a lot less scratches on the workpieces. Each part is optimally fixed and can then be processed further."



Bernhard Daxenberger – Schreinerei Daxenberger, Seon

"The bench area optimization that we carried out with BARTH started with the first vakuuLIFT about 3 years ago. Before that, we made experiments with simple lifting tables. But then we came to the conclusion that only the full version with vacuum clamping device and accessory program made sense for us. We are fully convinced of this solution."



Thomas Berer – Schreinerei Berer, Bad Birnbach

"After thinking about it for a long time, I replaced my hydraulic veneer press with a vacuum press from BARTH. Today I am happy that I took this step."



Open and honest advice

High quality standards

Innovative products

High value in use

Regional suppliers

Made in Germany